



INSTRUCTION BOOKLET

INTRODUCTION

Introduction

These instructions must be read by any person intending to use or service the machine.

Purpose of use

This equipment is expressly designed and intended for use for the shearing of sheep, goats and animals of the Camelidae family.

The machine should be used in a tidy, dry environment.

Contents

Electrical Safety	3
Mounting	4
Attaching flexible drive	5
Attaching solid drive	6
Attaching handpiece	7
Lubricating flexible driveshaft	8
Lubricating solid driveshaft	9
Troubleshooting	10
Wiring diagram	11
Motor - parts list	12
Motor - technical drawing	13
Flexible driveshaft - technical drawing	14
Solid driveshaft - technical drawing	15
Technical data	16



Important safety information

Battery Safety:

- Don't use a battery that looks damaged or is leaking
- Don't use a machine with damaged battery leads
- Don't smoke or allow naked flames anywhere near the battery
- Don't let any metal objects come in contact with the battery as these could cause a spark and possibly make the battery explode.
- Don't remove the power leads while the machine is running.

To connect your machine to a battery

1. Make sure your machine is switched off.
2. Connect the red lead to the positive (+) on the battery
3. Connect the black lead to the negative (-) on the battery

To disconnect your machine from the battery

1. Make sure your machine is switched off.
2. Remove black lead from negative (-) on the battery.
3. Remove red lead from the positive (+) on the battery

Secure fixing

The machine should be fixed securely when in use:

- This prevents damage to the electric flex and avoids electrical hazards
- Allows the spring to operate correctly when using a solid drive

Mount the machine so that the flexible drive is 20mm clear of the floor or for solid drives, 10mm clear of the floor.

Driveshafts should be set at least 400mm away from the wall.

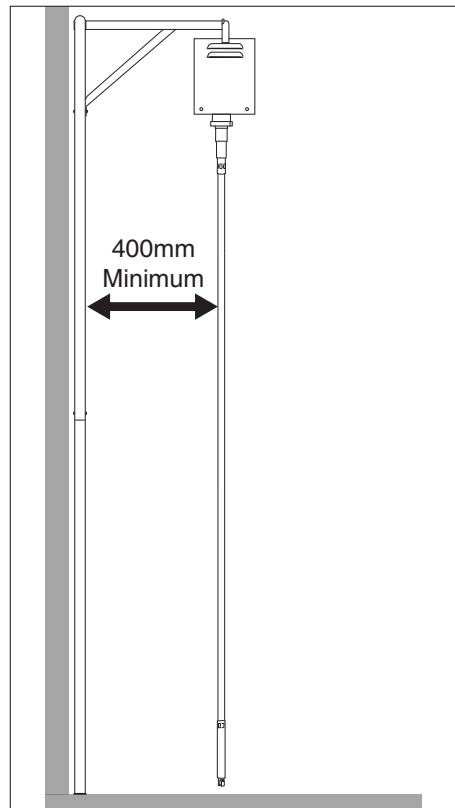
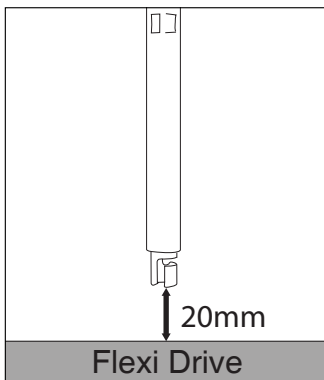
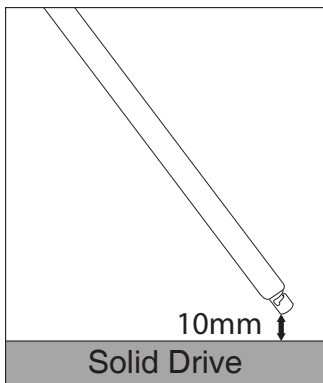

Flexible driveshaft

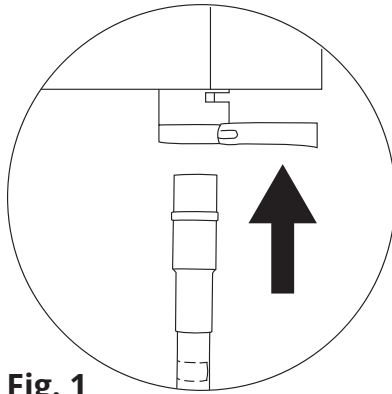

Fig. 1

Make sure the EasyDrive clamp is in the open position (Fig. 1) and then push up the outer driveshaft into the base casting of the machine until the top fitting reaches its shoulder stop (Fig. 2).

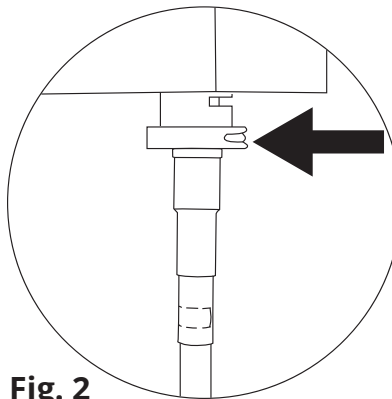

Fig. 2

Close the EasyDrive clamp to secure the outer drive in position, the inner drive connects automatically.

Be sure the outer driveshaft is clamped tightly, the clamp can be adjusted by screwing the clamp lever in or out before closing the clamp lever.

ATTACHING DRIVE

Solid driveshaft

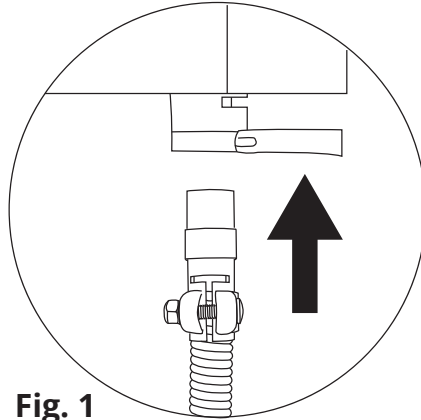

Fig. 1

Make sure the EasyDrive clamp is in the open position (Fig. 1) and then push up the long tube and spring into the base casting of the machine until the top fitting reaches its shoulder stop (Fig. 2).

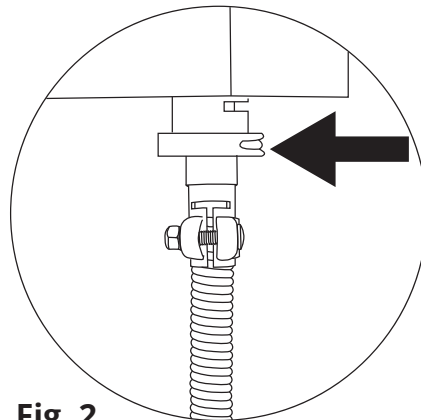

Fig. 2

Close the EasyDrive clamp to secure the outer drive in position, the inner drive connects automatically.

Be sure the driveshaft is clamped tightly, the clamp can be adjusted by screwing the clamp lever in or out before closing the clamp lever.

ATTACHING HANDPIECE

For pin drive machines

- Hang the machine up and attach the driveshaft
- Make sure the machine is turned off
- Push the handpiece onto the drive firmly
- Rotate clockwise, once you feel the handpiece locate into the bayonet, rotate another full time.

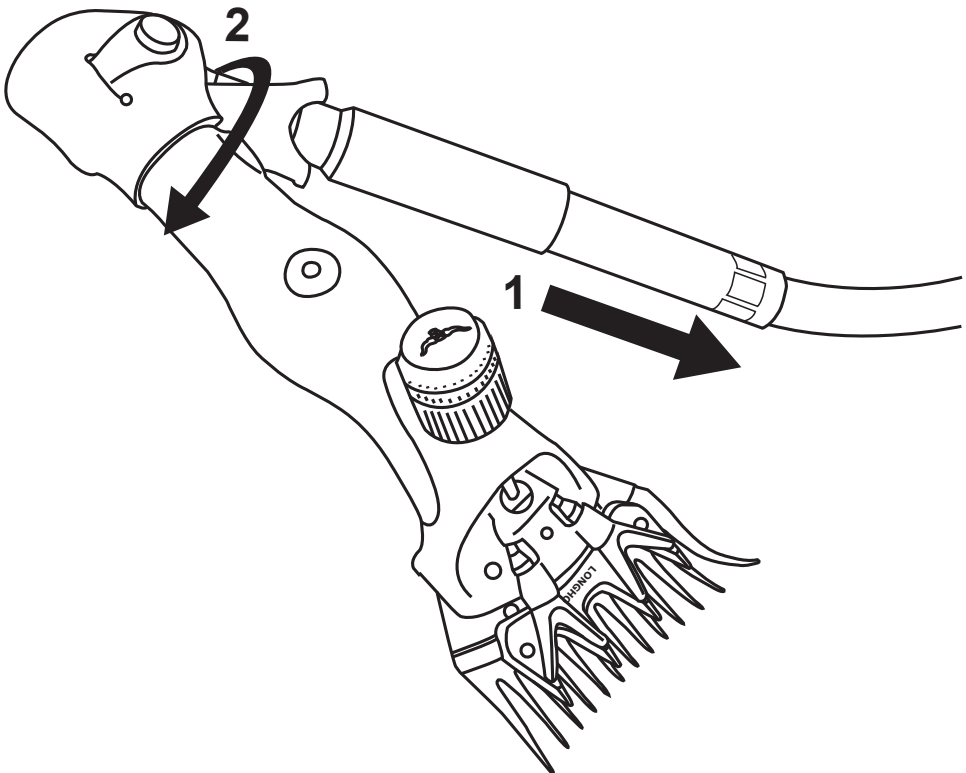

For worm drive machines

- Make sure the machine is turned off
- Push the handpiece onto the driveshaft firmly
- Rotate clockwise

FLEXI DRIVE LUBRICATION

Oiling the driveshaft

Frequency: after every 4 hours of use

Directions

- Remove the handpiece and the driveshaft
- Add oil into the top of the driveshaft
- Re-fit driveshaft to the machine

Greasing the driveshaft

Frequency: After every 40 hours of use or annually

Directions

- Remove the handpiece and the driveshaft
- Unscrew the top EasyDrive male fitting
- Unscrew the bottom bayonet fitting
- Pull the inner drive from the top of the outer drive
- Grease inner whilst feeding back into the outer
- Re-fit the bayonet end
- Re-fit the EasyDrive male fitting
- Attach driveshaft to the machine

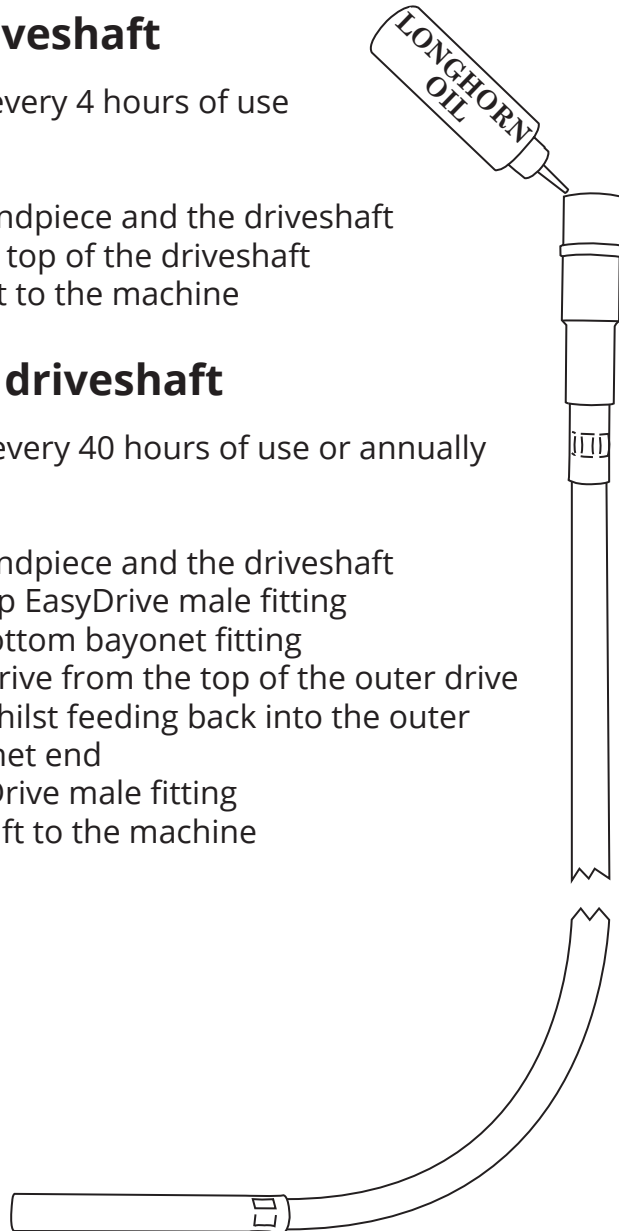

SOLID DRIVE LUBRICATION

Oiling the driveshaft

Frequency: After every 4 hours of use

Directions

- Remove the handpiece and the driveshaft
- Add oil into the top of the driveshaft (1)
- Add oil into the top of the long tube (2)
- Oil the elbow cogs (3)
- Oil the holes in the elbow joints (4 + 5)
- Add oil into the oil hole on the short tube (6)

Greasing the driveshaft

Frequency: After every 40 hours of use or annually

Directions (long gut)

- Unscrew the ferule from the solid elbow
- Unhook the long gut from the eye spindle
- Remove the long gut
- Refit the long gut whilst applying grease
- Hook the long gut onto the eye spindle
- Screw the ferule back onto solid elbow

Directions (short gut)

- Slacken the clamp on short tube
- Remove the short tube
- Grease the short gut
- Refit short tube
- Tighten clamp

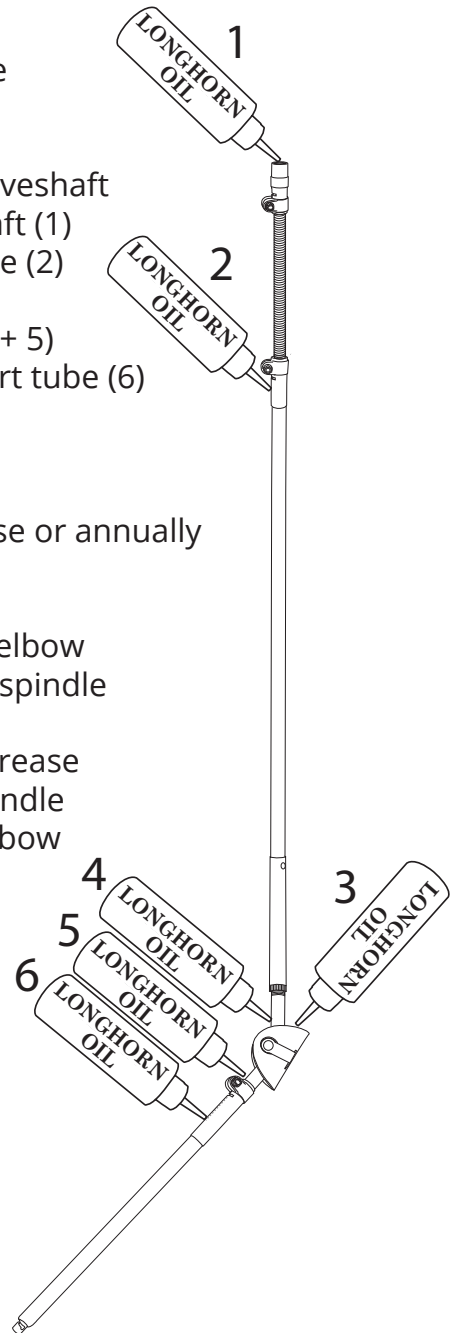

TROUBLESHOOTING

Problem	Cause	Solution
Motor does not start	Poor battery lead connections	Check connections and condition of wires / clips
	Faulty switch	Have switch replaced
	Damaged relay	Have relay replaced
	Burnt out motor	Have motor replaced
Motor struggles to start or runs slowly	Worn brushes	Have brushes replaced
Motor is noisy	Faulty bearings	Have bearings replaced
	Damaged cooling fan	Have cooling fan replaced
	Debris in the cooling fan	Remove debris or have machine serviced
Flexi drive is noisy	Lack of lubrication	Oil or grease the inner drive
	Damaged/worn inner drive	Replace inner drive
Solid drive is noisy / vibrates	Lack of lubrication	Oil or grease the guts
	Damaged/worn guts	Replace affected gut
	Dry spot on eye spindle	Have solid drive serviced
Cannot connect handpiece	Worn or broken bayonet/worm end	Replace bayonet/worm end
	Faulty/worn spring in bayonet end	Replace bayonet spring and/or bayonet end



Electrical work and servicing should only be carried out by suitably qualified personnel.

WIRING DIAGRAM

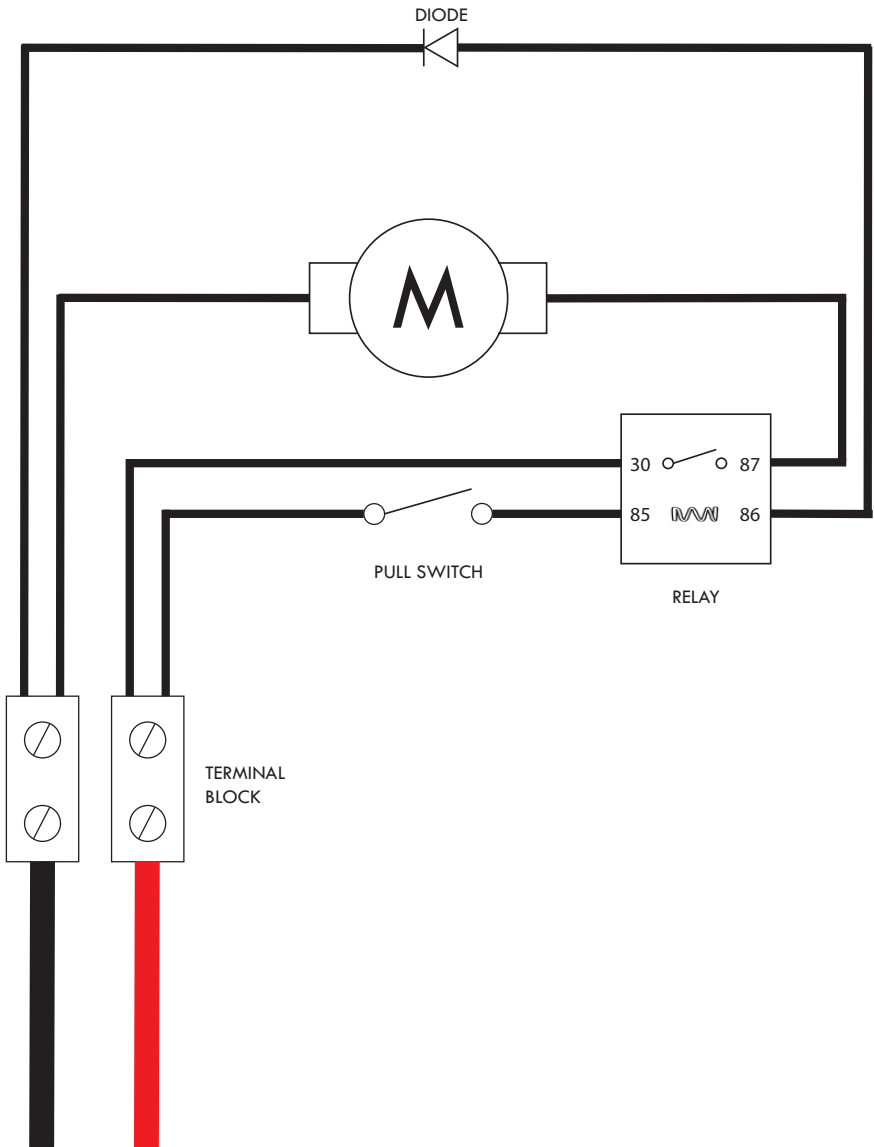

Parts list

Model	Drive Speed	Motor Rated Voltage	Power Consumption
3.2	3,200 RPM	12V - 14V	11A
3.5	3,500 RPM	12V - 14V	11A

1	Box Cover	18	Insulated Wire, Relay to Switch (1.5mm)
2	Base Plate	19	Insulated Wire, Terminal Block to Relay (4mm)
4	Motor - Model 3.2 (3,200RPM)	20	Insulated Wire, Terminal Block to Switch (1.5mm)
5	Motor - Model 3.5 (3,500RPM)	21	Brush
6	Female Coupling	22	Battery Lead Set
7	Drive Clamp	23	Crocodile Clip (Red)
8	Switch Mounting	24	Crocodile Clip (Black)
9	Switch	25	EasyDrive Casting
10	Relay 30 amp, 12 volt	26	Spring Pull Cord
11	Terminal Block	27	Pull Cord Rod
12	Bolt M5x12	28	Pull Cord
13	Bolt M5x20	29	Lock Nut
14	Shake Proof Washer	30	Gland
15	Insulated Wire, Relay to Brush (4mm)	31	Bolt M5x20
16	Insulated Wire, Terminal Block to relay with Diode (1.5mm)	32	Bolt M5x12
17	Insulated Wire, Terminal Block to Brush (4mm)	33	Shakeproof Washer

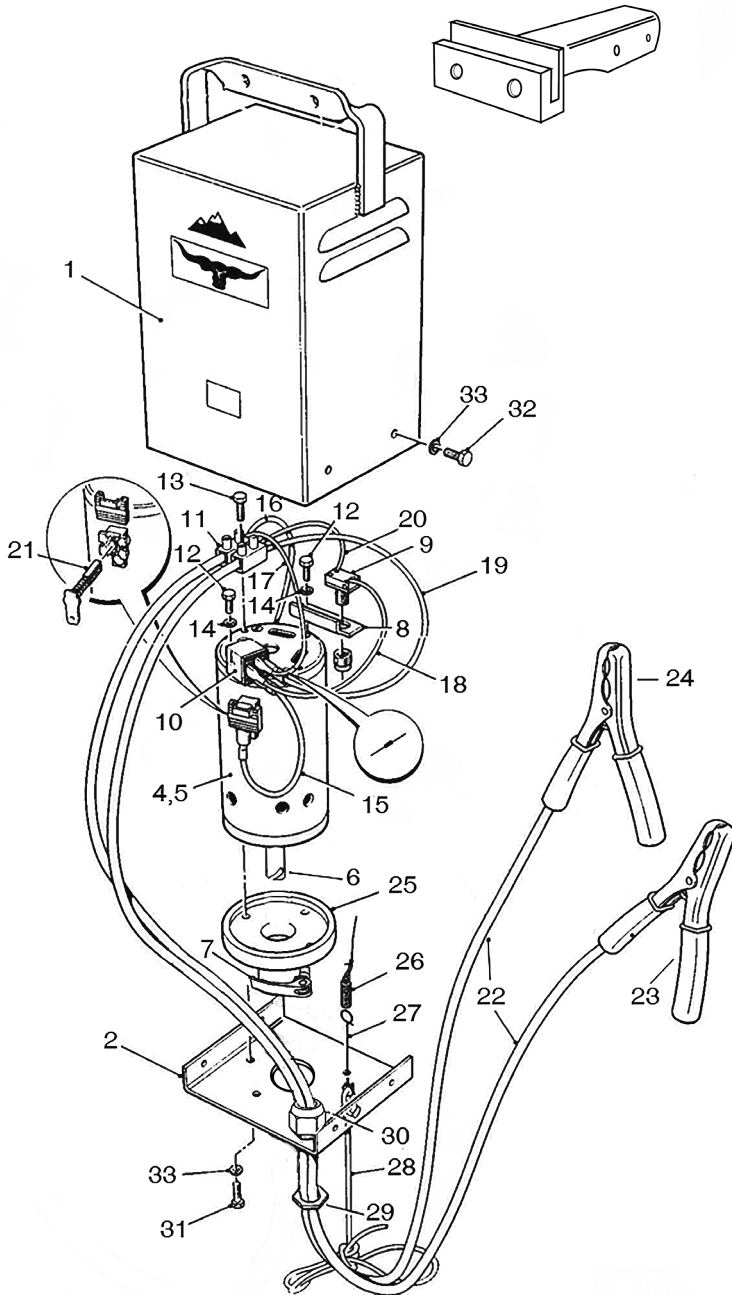

FLEXI DRIVESHAFT

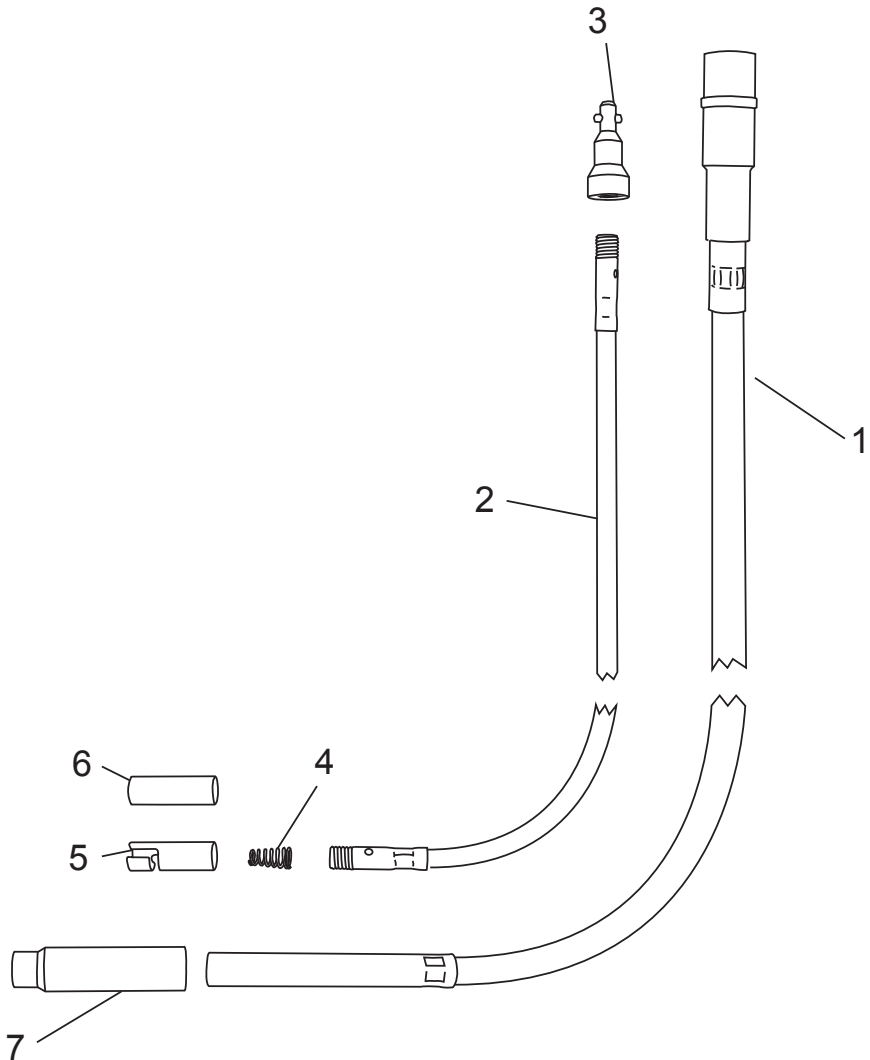

1	H11-507	Outer	4	H18-020	Bayonet Spring
2A	H11-505	Inner (Pin)	5	H49-100	Bayonet End
2B	H11-506	Inner (Worm)	6	H49-102	Worm End
3	H11-039	Male Coupling	7	H49-002	Flexi Ferule

SOLID DRIVESHAFT

1	H18-002	EasyDrive Spring Coupling
2	H18-003	Lock Nut
3	H18-004	Long Lug Bolt
4	H18-005	Spring
5	H18-006	Long Tube
6	H18-007	Ferule
7	H18-008	Eye Spindle
8	H18-009	Elbow Joint
9	H18-010	Solid Cog
10	H18-011	Elbow Guard
11	H18-012	Joint Cap
12	H18-013	Joint Spring
13	H18-014	Short Lug Bolt
14	H18-015	Short Tube
15	H18-016	Short Gut (Pin)
16	H18-017	Shot Gut (Worm)
17	H18-018	Long Gut (EasyDrive)
18	H49-101	Gut Hook
19	H49-100	Bayonet End
20	H49-102	Worm End
21	H11-039	EasyDrive Male Coupling

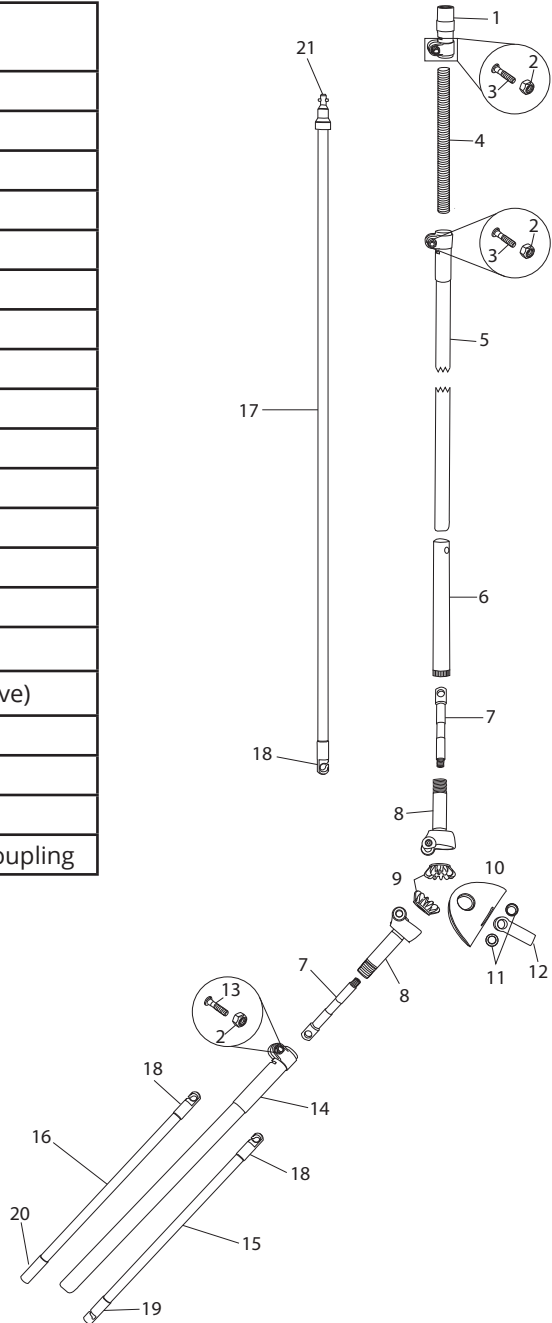



LONGHORN

12V



Manufactured by Horner Shearing

Lane Side • West Bradford • Clitheroe • BB7 4QH • United Kingdom