

Dehorner Instructions

#707310

The Rhinehart X-50 is a powerful 110v plug-in dehorner designed to stop the growth of horn cells in livestock.

The dehorner arrives to you from Premier with a goat-sized tip attached and ready for use.

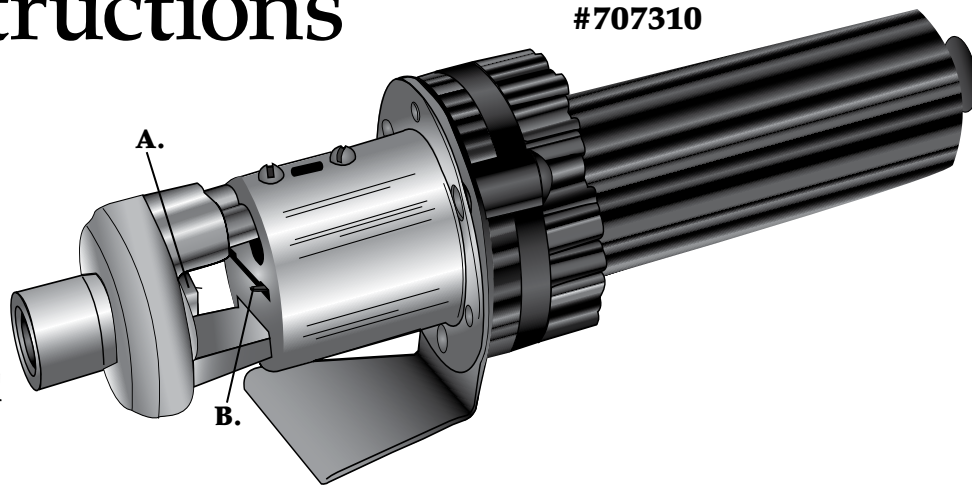

1. If you prefer/need the larger cattle tip, make sure the unit is unplugged and has cooled down (**Warning—temperature can exceed 1000 degrees Fahrenheit**). To remove the tip, hold it with a tool or your hand and unscrew the bolt and washer (**A.**) located on the underside.
2. The lever on the dehorner (**B.**) should remain at “D” for all dehorning. The “S” is for those that have the tip for soldering.

3. Allow 10 – 12 minutes for the dehorner to heat up before using. Apply to the horn base for approximately 10 seconds. For more detailed instructions, reference Rhinehart’s directions.



800-282-6631

www.premier1supplies.com

Washington, IA

© Copyright 2016, Premier1Supplies.
All rights reserved.