



OPERATING INSTRUCTION

Electric Fence Energiser

Read full instructions before use!



2031 300th Street · Washington, IA 52353
www.premier1supplies.com
800-282-6631 · 319-653-7622



made in Germany
by horizont group gmbh
Division agrartechnik



INTELLISHOCK 31:

Voltage at no load:
max. 11400

Voltage at 500 Ω
(animal contact):
max. 4700 V

Max. fence line length:
49 mi (CEE)

Requirements:

The energizer complies with
the International Safety
Standard IEC 60335-2-76 +
EN 60335-2-76.



SPARE PARTS

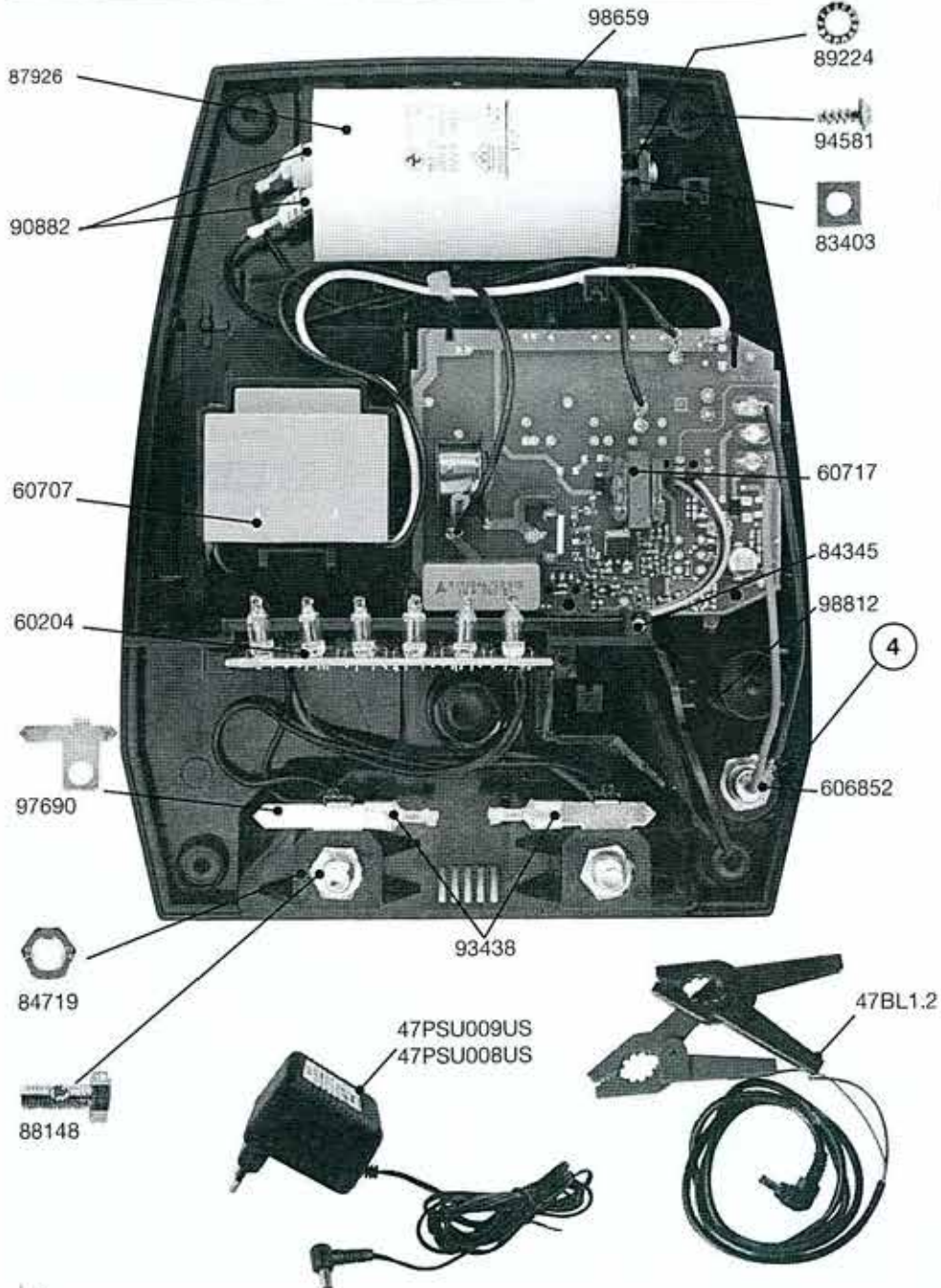

INSTALLATION AND CONNECTION

Fig. 1

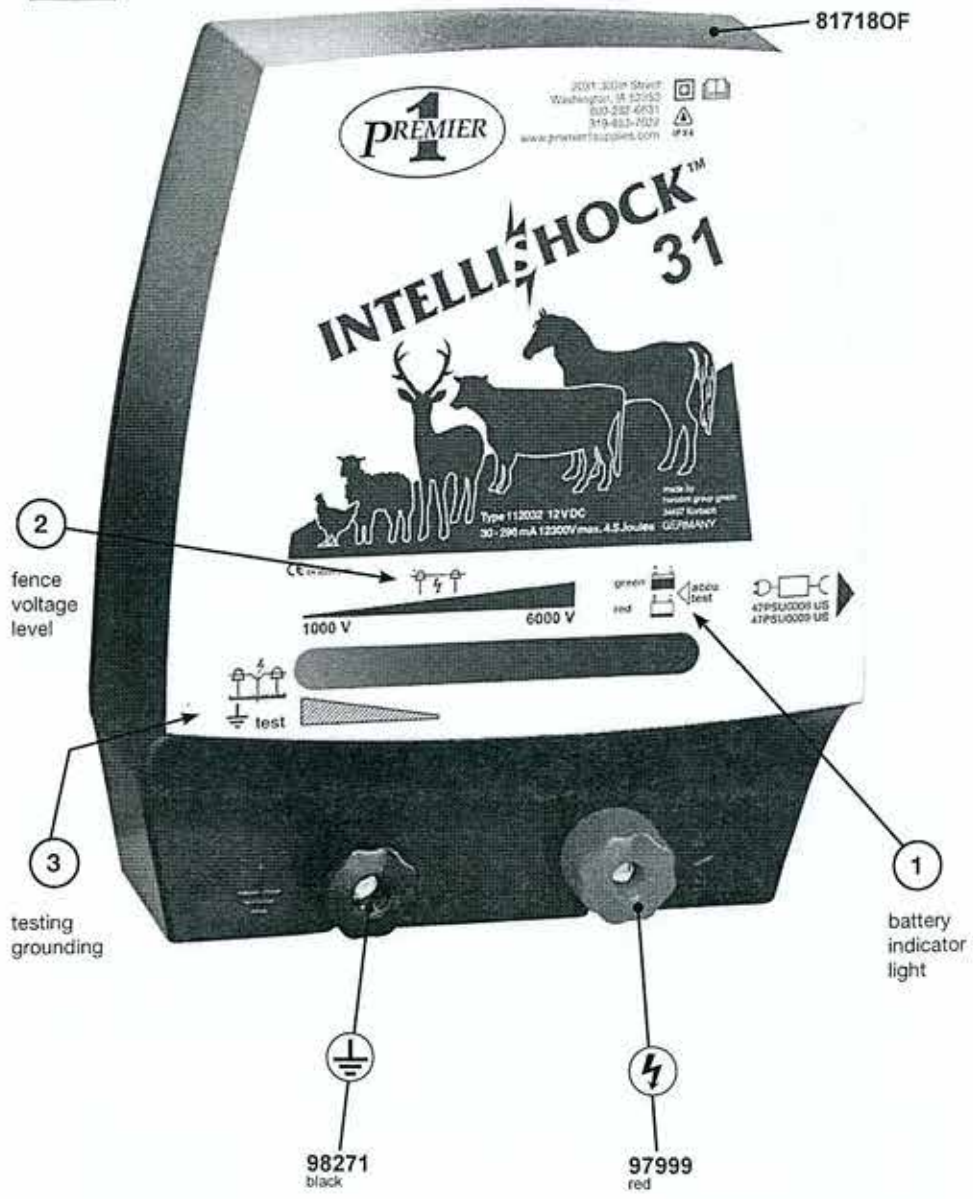

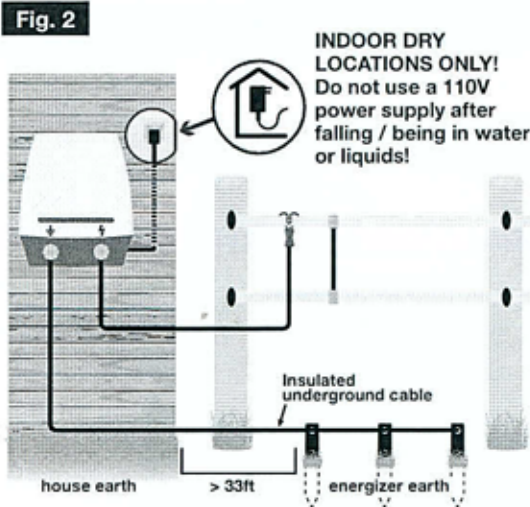

For 110V operation the energizer and the mains power supply (AC adapter) must be protected from direct rainfall.

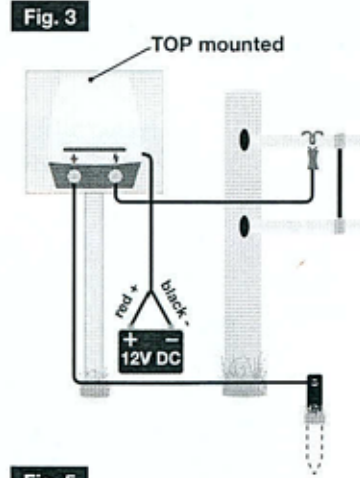

For the connection with mains (100-120V AC) use only the delivered Power Supply 47PSU0009US or an alternative 47PSU0008US as indicated on the front of the electric fence energizer.

A. OPERATING INSTRUCTION FOR ELECTRIC FENCE ENERGIZER INTELLISHOCK 31

Read and mind all operating instructions and safety hints for the safe use, installation and operation!

INSTALLATION AND CONNECTION:

For 110V installation, the energizer must be mounted indoors inside a building but not where there is a risk of fire! If used outdoors, the energizer must be mounted vertically with itself and the 110V power supply protected against direct rainfall. Alternatively if the energizer is connected to a 12V battery outdoors, it should be mounted vertically. Fence and earth leads must be attached to the marked fence and earth terminals (see Fig. 2 & 3).

Attach the 12V-connection cable (47BL.1) to a fully charged 12V deep cycle battery or alternatively plug in the 110V power supply (12V / 100 - 120V PSU0009US) to a 110V AC outlet making sure that the energizer and 110V plug is protected from direct rainfall. After a few seconds a slight tic-tac can be heard. The control lamp flashes green with the pulses.

Warning! Disconnect power before making changes to fence or earth wiring! Mount out of reach of children!

GROUNDING:

For a faultless operation and to obtain best possible output a good grounding is very important. Therefore the grounding must be made at a rather moisty and overgrown place. We recommend to use at least 3 pieces of 1m (3 ft) ground rod or t-posts for IntelliShock 31. An additional or deeper ground rod may improve the earthing. The distance between the system earth (grounding) and other earth systems (e.g. telephone, mains power, anti-lightning or other earth systems of another energizers) shall be at least 10m (33ft).

SERVICE OF DOUBLE INSULATED APPLIANCES:

In a double insulated controller, two systems of insulation are provided instead of grounding. No equipment grounding means is provided in the supply cord of a double-insulated controller, nor should a means for equipment grounding be added to the controller. Servicing a double insulated controller requires extreme care and knowledge of the system, and should be done only by qualified service personnel. When servicing, use only identical replacement parts. A double insulated controller is at least marked with symbol for double insulation, if not marked with the word „DOUBLE INSULATION“ or „DOUBLE INSULATED“.

The energizer has a pulse interval of 1 to 1.5 seconds. If the interval is less than 1 second the energizer is to be repaired, if the interval is more than 1.5 seconds the fence is not longer safe in function and must be repaired, too. Lightning damages can be recognized by burned traces. In this case return the energizer to service station.

 **CAUTION:** The energizer should only be opened or repaired by qualified personnel, to reduce the risk of electric shock!

DUTY TO THE PUBLIC:

Safe electric fence construction - read and respect in conjunction with B. SAFETY HINTS ELECTRICAL ANIMAL FENCES. Electric fence can be hazardous when there is a risk of entrapment or entanglement, or other hazards exist. Serious injury or death may result. Take all steps to avoid the risk of entrapment or entanglement. Fasten warning signs to electric fence posts or wires at frequent intervals along any public roads or pathways. Incorporate a non-electrified gate or stile where an electric animal fence crosses a public pathway and fasten warning signs to fence posts or wires adjacent to the crossing."

PRECAUTIONS AGAINST LIGHTNING DAMAGES / LIGHTNING SUPPRESSION IN BUILDINGS TO PREVENT FIRE:

To prevent damages caused by lightnings the connection lead must have a lightning gap in series before entering the building. Furthermore the energizers being installed inside buildings and supplying outside fences shall not be installed at places where there is a risk of fire, e.g. barn, stables etc. The lightning suppression device must be installed by a competent person. According to experience mains energizers are more subject to lightning damage than battery energizers, so it is recommended to use lightning arrester kit. The installation is to carry out according to fig.1. The system earth of the electric fence shall be galvanically connected to the earthing system of the lightning arrester. If the connection lead is led away from a building a lightning arrester must be installed. Electric fences not being operated shall be connected to earth.

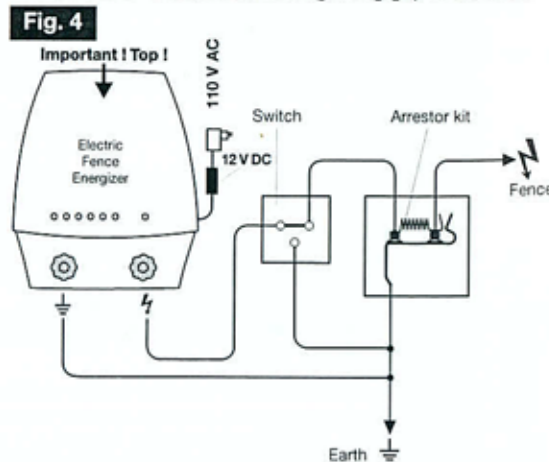

B. SAFETY HINTS ELECTRIC ANIMAL FENCES

General hints for the safe use, installation and operation

PART 1: PRINCIPLES AND LIMITATIONS OF ELECTRIC FENCING FOR ANIMALS

An electric fence consists of an energizer and a connected fence where the energizer feeds electric impulses into the fence. The electric animal fence represents a "psychological barrier" for the animals; it keeps animals inside or outside a certain area, it can also be used to train a certain behaviour (e.g. cow trainer in the stable). The electric security fence is used for security purposes that comprise an electric fence and a physical barrier electrically isolated from the electric fence.

No electric or mechanical fence can guarantee a 100% effective solution in protecting or containing your animals. The effectiveness of an electric fence may vary upon the unique local conditions within which the fence is installed. A suitable combination of products together with competent installation will ensure the best results. On occasion a determined animal may overcome the most rigid of mechanical fences or the most comprehensive electric fence system. **For this reason the seller gives no assurance that the fence system is 100% safe against outbreak.** A well installed electric fence can offer a high level of security when compared to a mechanical fence, as the psychological barrier an electric shock can represent will deter the animal from finding a way to circumnavigate the fence. Electric fences will also offer far greater level of flexibility.

PART 2: WARNING SAFE ELECTRIC ANIMAL FENCES

Read and mind before using – WARNING:

- This appliance is not intended for use by persons (including children) with reduced physical, sensory or mental capabilities, or lack of experience and knowledge, unless they have been given supervision or instruction concerning use of the appliance by a person responsible for their safety. Children should be supervised to ensure that they do not play with the appliance.
- Never touch an electric fence wire with your head, mouth, neck or torso. Never allow anyone else to do so. Instruct all visitors and children to never do so. Do not climb over, through or under a multi-wire electric fence. Use a gate or a specially designed crossing point.
- To avoid any risks with head, mouth, neck or torso contacts do use only smaller energizers or the lower output of a stronger energizer on fences near children and untrained adults. With high joule energizers reduce the available energy on wires near children or untrained adults with a 500 ohm resistor. To do so, change the fence design or management to reduce the weed to wire contact, if necessary.
- Keep a distance of at least 2,5 m (8,3 ft) with the electric fence to all metallic parts i.e. to water-pipes and troughs especially if persons can be in the vicinity.
- Do not connect simultaneously to a fence and to any other device such as a cattle trainer or a poultry trainer. Otherwise, lightning striking your fence will be conducted to all other devices - Risk of Electric Shock.
- Do not place combustible materials near the fence or Energizer connections. In times of extreme fire risk, disconnect Energizer.
- If there is a danger of over-flooding, the energizer must be turned off.
- Help to avoid any misuse of the energizer by:
 - - Observing the printing
 - - Secure the energizer against un-allowed access (e.g. anti-theft or anti-children equipment) if the location make this necessary
- Check your local ordinance for specific regulations
- **Read and mind Annex BB.1 of the International Safety Standard IEC 60335-2-76 + EN 60335-2-76.:**

Electric animal fences and their ancillary equipment shall be installed, operated and maintained in a manner that minimises danger to persons, animals or their surroundings.

WARNING: Do not touch the fence with the head, mouth, neck or torso. Do not climb over, through or under a multi-wire electric fence. Use a gate or a specially designed crossing point.

Electric animal fence constructions that are likely to lead to the entanglement of animals or persons shall be avoided.

An **electric animal fence** shall not be supplied from two separate **energizers** or from independent **fence circuits** of the same **energizer**.

For any two separate **electric animal fences**, each supplied from a separate **energizer** independently timed, the distance between the wires of the two electric animal fences shall be at least 2,5 m (8,3 ft). If this gap is to be closed, this shall be effected by means of electrically non conductive material or an isolated metal barrier. Barbed wire or razor wire shall not be electrified by an **energizer**.

A non-electrified fence incorporating barbed wire or razor wire may be used to support one or more off-set electrified wires of an **electric animal fence**. The supporting devices for the electrified wires shall be constructed so as to ensure that these wires are positioned at a minimum distance of 150 mm from the vertical plane of the non-electrified wires. The barbed wire and razor wire shall be earthed at regular intervals.

Follow the energizer manufacturer's recommendations regarding earthing.

A distance of at least 10 m (33ft) shall be maintained between the **energizer earth electrode** and any other with the earthing system connected parts such as the power supply system protective earth or the telecommunication system earth.

Connecting leads that are run inside buildings shall be effectively insulated from the earthed structural parts of the building. This may be achieved by using insulated high voltage cable. Use this lead-out cable in buildings and where soil could corrode exposed galvanised wire. Never use household electrical cable: it is made for a maximum of 600 volts and will leak electricity.

Connecting leads that are run underground shall be run in conduit of insulating material or else insulated high voltage cable shall be used. Care must be taken to avoid damage to the connecting leads due to the effects of animal hooves or tractor wheels sinking into the ground.

Connecting leads shall not be installed in the same conduit as the mains supply wiring, communication cables or data cables.

Connecting leads and **electric animal fence** wires shall not cross above overhead power or communication lines.

Crossings with overhead power lines shall be avoided wherever possible. If such a crossing cannot be avoided it shall be made underneath the power line and as nearly as possible at right angles to it.

If **connecting leads** and **electric animal fence wires** are installed near an overhead power line, the clearances shall not be less than those shown in Table BB1.

Table BB 1 - Minimum clearances from power lines for electrical animal fences

Power line voltage (V)	Clearance (m)
≤ 1000	3 (10 ft)
> 1000 and ≤ 33000	4 (13 ft)
> 33000	8 (27 ft)

If **connecting leads** and **electric animal fence** wires are installed near an overhead power line, their height above the ground shall not exceed 2m (6ft)

This height applies to either side of the orthogonal projection of the outermost conductors of the power line on the ground surface, for a distance of

- 2 m for power lines operating at a nominal voltage not exceeding 1000 V;
- 15 m for power lines operating at a nominal voltage exceeding 1000 V

Electric animal fences intended for deterring birds household pet containment or training animals such as cows need only be supplied from low output energizers to obtain satisfactory and safe performance.

In **electrical animal fences** intended for deterring birds from roosting on buildings no fence wire shall be grounded if the fence wires are not connected to metal parts. If one wire is connected with a metal part (i.e. a gutter) or a metal structure of the building these metal parts must be grounded.

A warning sign shall be fitted to every point where persons may gain ready access to the conductors.

Where an **electric animal fence** crosses a public pathway, a non-electrified gate shall be incorporated in the **electric animal fence** at that point or a crossing by means of stiles shall be provided. At any such crossing, the adjacent electrified wires shall carry warning signs. In areas of public access, use an electric fence warning sign (G6020) every 10m (33ft) to identify the electrified wire(s).

Any part of an **electric animal fence** that is installed along a public road or pathway shall be identified at frequent intervals by warning signs securely fastened to the fence posts or firmly clamped to the fence wires.

The size of the warning sign shall be at least 100 mm x 200 mm (4 inch x 8 inch).

The background colour of both sides of the warning sign shall be yellow. The inscription on the sign shall be black and shall be either

- the symbol of Figure BB1, or
- the substance of **CAUTION: Electric fence.**

The inscription shall be indelible, inscribed on both sides of the warning sign and have a height of at least 25 mm (10 inch).

Ensure that all mains-operated, ancillary equipment connected to the electric animal fence circuit provides a degree of isolation between the fence circuit and the supply mains equivalent to that provided by the energizer.

NOTE 1 Ancillary equipment that complies with the requirements relating to isolation between the fence circuit and the supply mains in Clauses 14, 16 and 29 of the standard for the **electric fence energizer** is considered to provide an adequate level of isolation.

Protection from the weather shall be provided for the ancillary equipment unless this equipment is certified by the manufacturer as being suitable for use outdoors, and is of a type with a minimum degree of protection IPX4.

Read and mind for special applications

- Of electric fences in pastures: Train livestock to Power Fencing prior to entry into pastures. Allow livestock to approach a Power Fence for the first time without stress.
- of **electric fences in zoos and game reserves**: The mounting of such installations may only be carried out by trained specialist, a mechanical barrier must be provided which separates the electric fence from visitors.
- of Game Fencing: Power Fencing has been used widely throughout the world for game animals, deer, bears, elk and elephant. Power Fences are a psychological barrier and should not be considered a complete physical barrier fence. With any Power Fence occasional animal penetration may occur (as with any other type of fence). It is important for game fencing to have power on the fence the same day as the fence is constructed. Animals investigating the new obstruction will be shocked and will relate the shock to the new obstruction. If no power is on the fence and animals learn to walk through the fencing system with no electric shock, this causes major problems later on since they will not relate the electric shock to the fence after the power is turned on. A Power Fence is not recommended for animals under hunting pressure. For specific questions on game fencing contact your dealer.
- of Bird Determent: Where the Energizer is used to supply a system of conductors used for deterring birds from roosting on buildings, no conductor should be connected to earth. A switch should be installed to provide means of isolating the Energizer from all poles of the supply and clear warning signs should be fitted at every point where persons may have ready access to the conductors. The notice should bear the words "LIVE WIRES" in block letters not less than 13mm (½" high). The letters should be red on a white background. Each notice should be at least 62mm x 50mm (2½" x 2").

PART 3: SAFETY HINTS ELECTRIC ANIMAL FENCES
- To Reduce Risk and Liability ...

REMEMBER:

Never touch an electric fence wire with your head or upper torso (see photo at right).

Never allow anyone else to do so. Instruct all visitors and children to never do so.

Risk and Liability Reduction Methods

1. For reasons not fully understood, contact with the spinal & head area is much worse than contact with hands, arms or legs.
2. Most experts agree that smaller energizers are safer than large ones (as long as animal control is not put at risk). So use smaller energizers on fences near children and untrained adults. To do so, change the fence design or management to reduce the weed to wire contact.
3. Never connect two energizers to one wire at the same time.
4. Never energize barbed wire.
5. With high joule energizers reduce the available energy on wires near children or untrained adults with a 500 ohm resistor. (Not illustrated here.)
6. Hang warning signs on the fence at critical areas where children or untrained adults will encounter them (inset at right).
7. Where practical do not energize wires less than 12 in. above the soil. Why? To allow humans that might contact a wire enough space to fall (by gravity) away from any energized wires.
8. Ensure that all energized wires are on the inside of your boundary fence (ensuring that anyone who touches them without your permission is a trespasser). For boundary fences achieve this with internal energized offset wires.
9. The shock from electric fences can panic animals who may in turn crash into fences (or people) resulting in injury to one or both. Horses have been known to rear and throw their rider-resulting in injuries to both.

To reduce this risk:

- a. Build only non-electric fences along horse trails, around livestock corrals and surrounding lots.
- b. Reduce the available volts and joules on fences that enclose very small areas (e.g. night enclosures) thus reducing panic and stress.



*Never allow your head to get near an electrified wire. This photo was taken to illustrate what **not** to do.*

Accidental head/neck contact can occur when pushing a voltage probe into the soil when checking voltage. Be very careful when you do so to avoid head to wire contact.

A fence that is exposed to untrained adults or children should never be without warning signs. Without them your liability may well be higher.

TECHNICAL DATA

12 V DC | 33 - 296 mA | 12300V max. | Input: 4.5 Joules
 12V/ 100-120V AC 0.8-4.5 Watt per hour

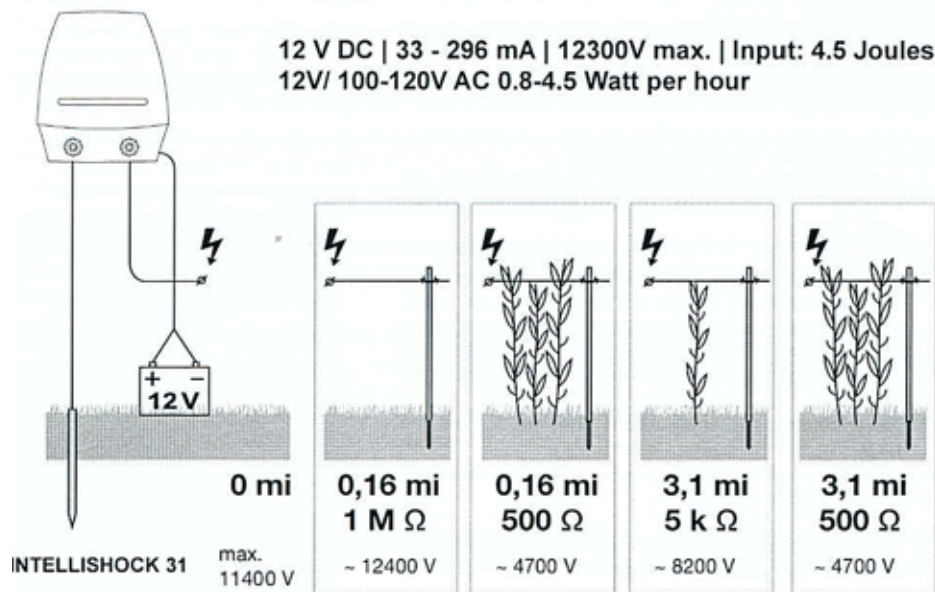

CEE: MAX. FENCE LINE LENGTH

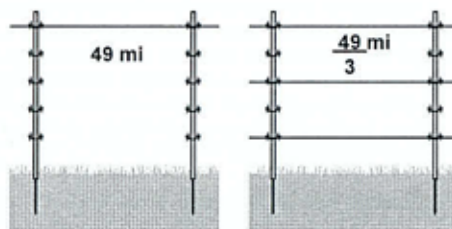

SUBJECT TO TECHNICAL ALTERATIONS !

12V DC: Use only rechargeable 12V deep cycle batteries. Batteries should always be (re)charged before use, after use, during longer storage (i.e. after more than 2 month) or when 60% discharged (down to 40% capacity) to avoid damaging the battery. Please be aware that these values can vary due temperature.

The battery indicator light „accu-test“

- is flashing green: 12V DC battery is (fully) charged or 110V AC is working
- is flashing red: 12V DC SLA battery is very flat (less than 20% capacity) and must be recharged **instantly!**
- no light: energizer is not working because of 12V DC flat battery or 110V AC is not provided or malfunction of the energizer

SLA batteries:

Recharge when battery capacity is less than 40% which is normally after **8 days** on a weedy fence with a 12V 100 ampere hour battery ($100\text{Ah} \cdot 60\% / 24\text{h} / 0.296\text{A} = 8.44$ days) or normally after **75 days** on a clean fence with a 12V 100 ampere hour battery ($100\text{Ah} \cdot 60\% / 24\text{h} / 0.033\text{A} = 75.75$ days). Deep cycle batteries will normally withstand repeated discharges as low as 40% and still fully recharge during repeated cycles.

Vented Lead Acid batteries, if used:

During charging lead-acid batteries must be placed in a well-ventilated area.

For use, charging and storage read and mind all additional instructions of the battery supplier.



2031 300th Street - Washington, IA 52353
www.premier1supplies.com
800-282-6631 · 319-653-7622



made in Germany
by horizont group gmbh
Division agrartechnik