

Operating Instruction INTELLISHOCK 88B

in connection with SECURA safety and installation hints for electric fence energizers

Installation and connection:

Install the energizer near the fence, out of reach of livestock. Drive the energizer ground rod or rods into a moist area. Good grounding is very important for proper operation of the energizer and fence. Connect ground wire to ground terminal, then ground rods. Connect the fence lead to fence energizer terminal, then to fence.

Operation and control: (fig.1)

Press switch **S2** into desired position (full power or reduced power). Press switch (**S1**) in position **ON**. After a few seconds you will hear a humming sound and the operating indicator light flashes in the rhythm of the impulses. The energizer is supplying voltage onto the fence.

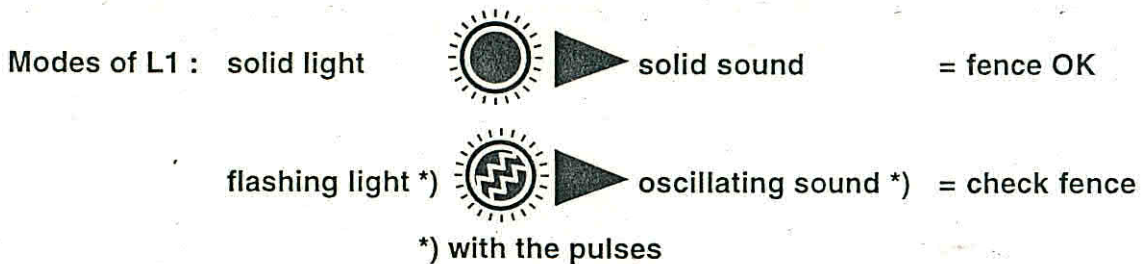

With no visible or audible signals either the battery is discharged or there is a fault in the energizer. In case of a well insulated fence the energizer consumes only 0.2 A (0.12A) , in case of bad insulation 0.65A (0.4A).

If the button **T** is pressed the fence control lamp **L3** flashes with the pulses. The better the insulation, the brighter the flashing.

If the energizer is to be turned off, the T-button must be pressed down for a full 15 seconds. This avoids residual charges in the fence - no charge, no illumination. IF THIS IS NOT DONE, THE FENCE WILL STILL BE ENERGIZED.

Battery test:

With **S1** in position **TEST** the state of discharge of the battery can be checked. If the battery charge is still okay, **L2** is permanently illuminated. If not, **L2** is dark. After the battery check **S1** must be set again in position **ON**.

Requirements:

The energizer corresponds to the standards EN 61011-2 and 89/336/EEC (CE).

Change of battery: Open the unit according to (fig.3) and change or insert battery.

Solar operation:

On request, a 10W solar panel is available that can be mounted on top of the energizer and be directed towards the south (fig. 4). The 10W panel is not capable of completely charging the battery, especially if in the more powerful position. The 10W panel will only extend the operation time of the 12V battery depending upon the sun intensity. However, with a 20W panel you can fully recharge the battery while operating the standard output terminal.

Technical changes reserved !

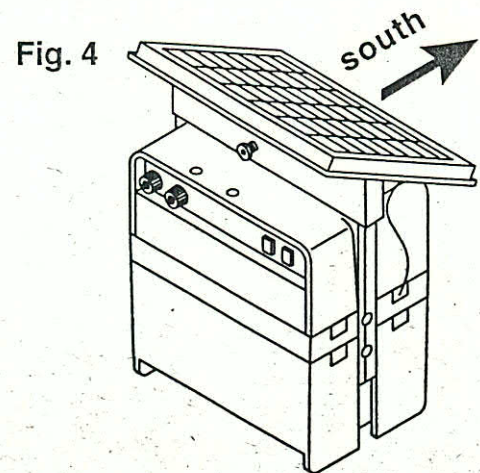
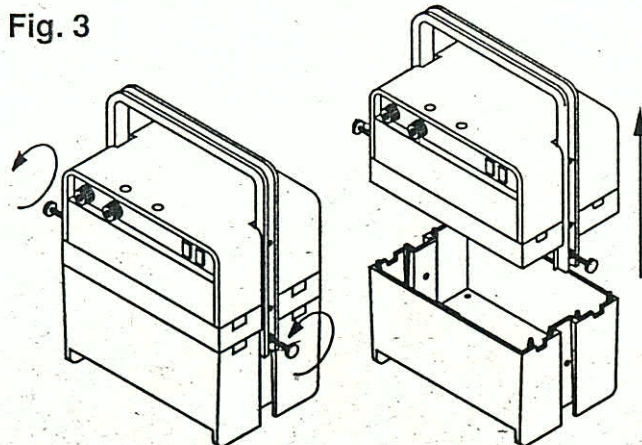
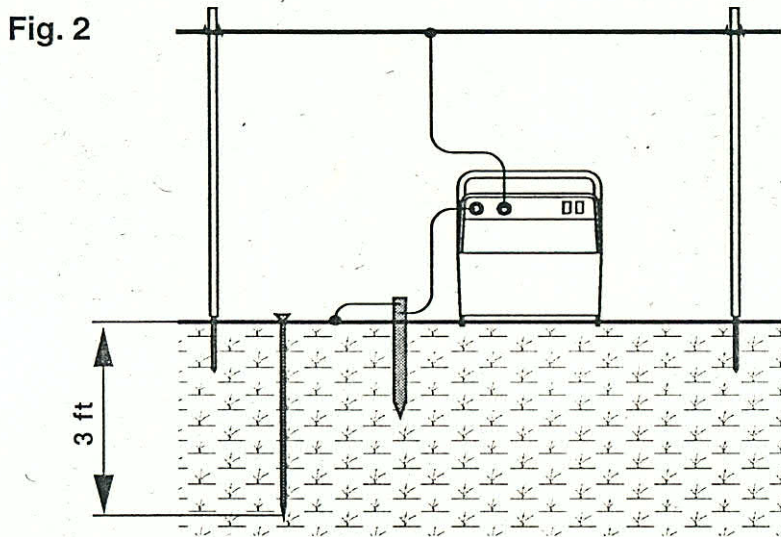
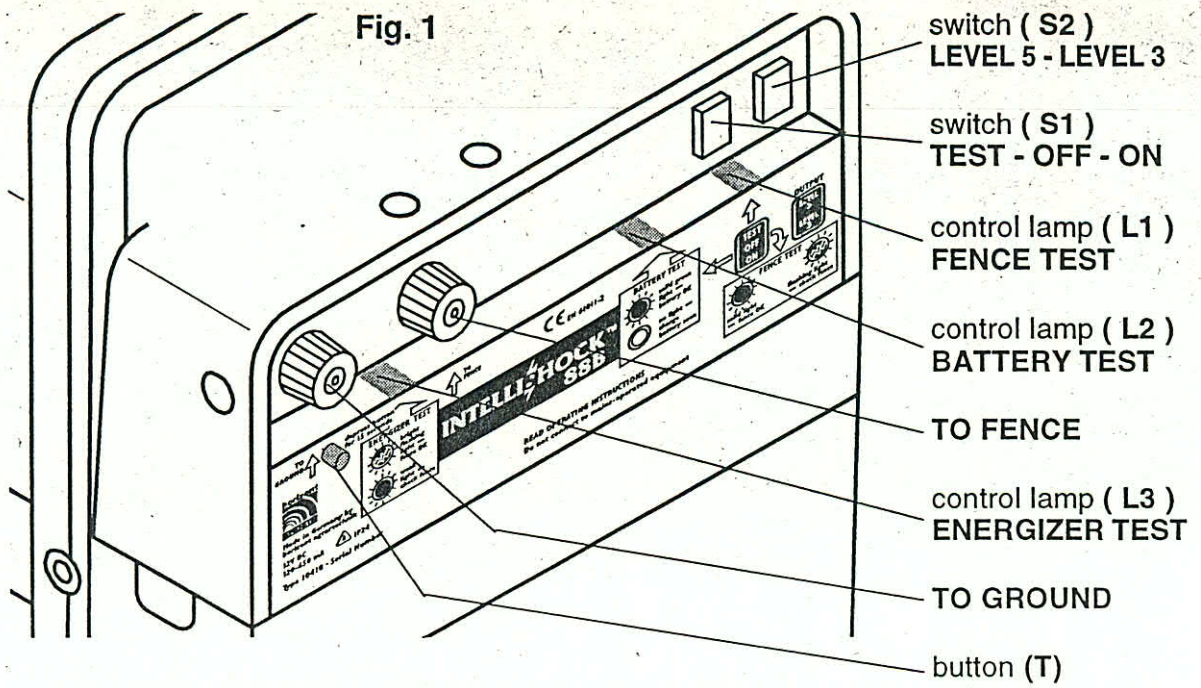

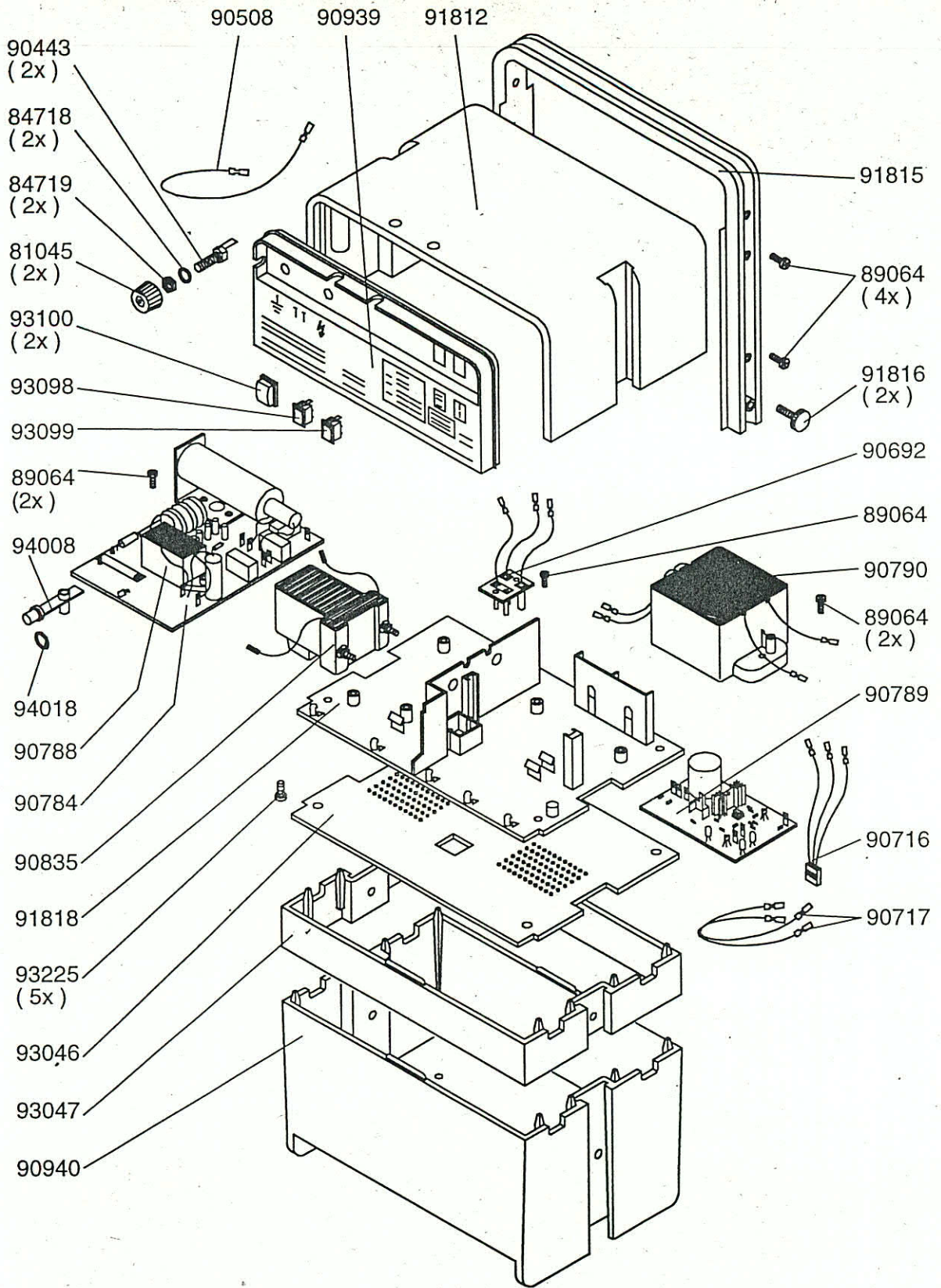

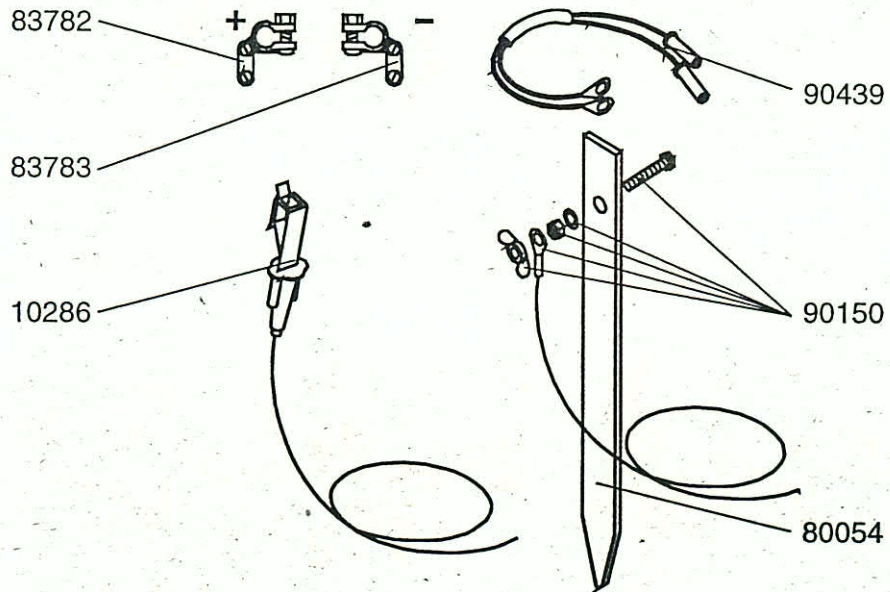
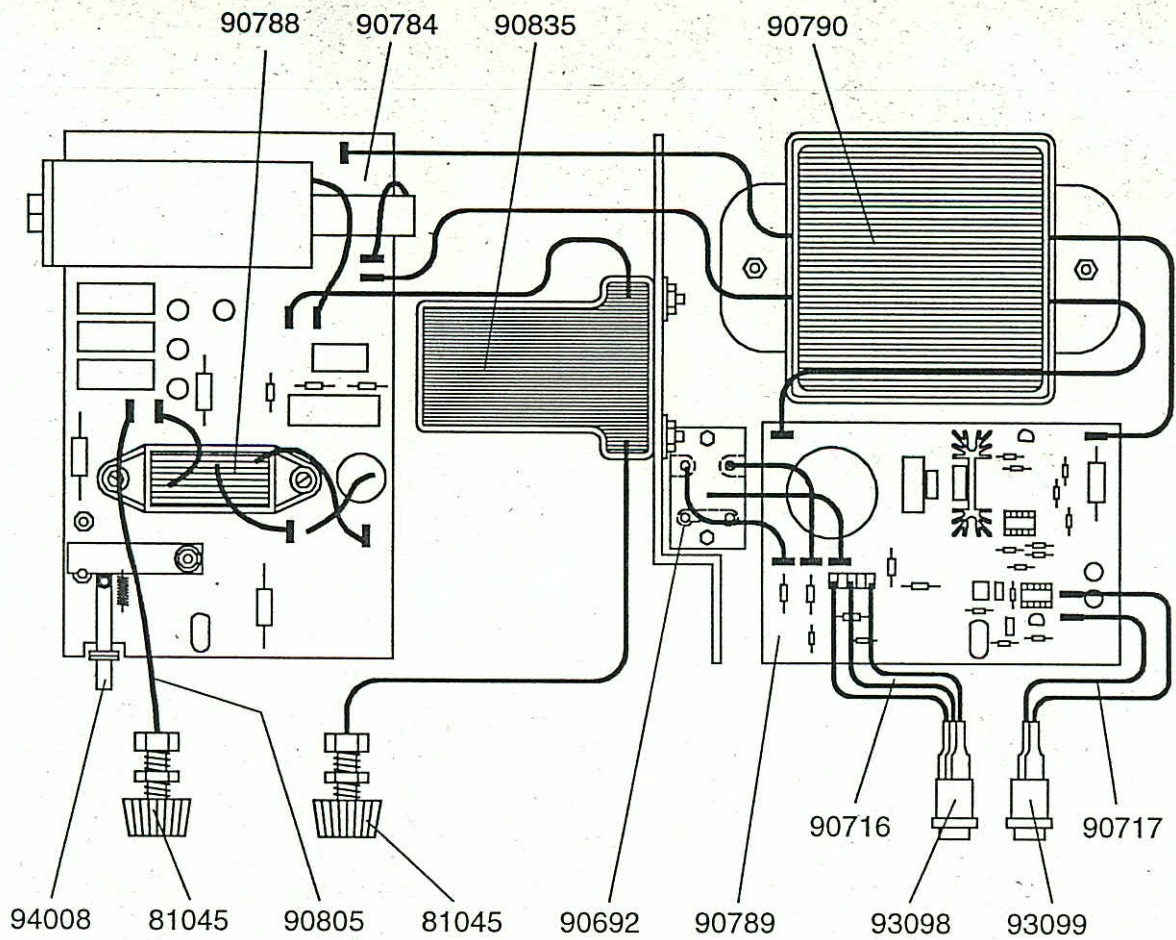

88B

Technical Data

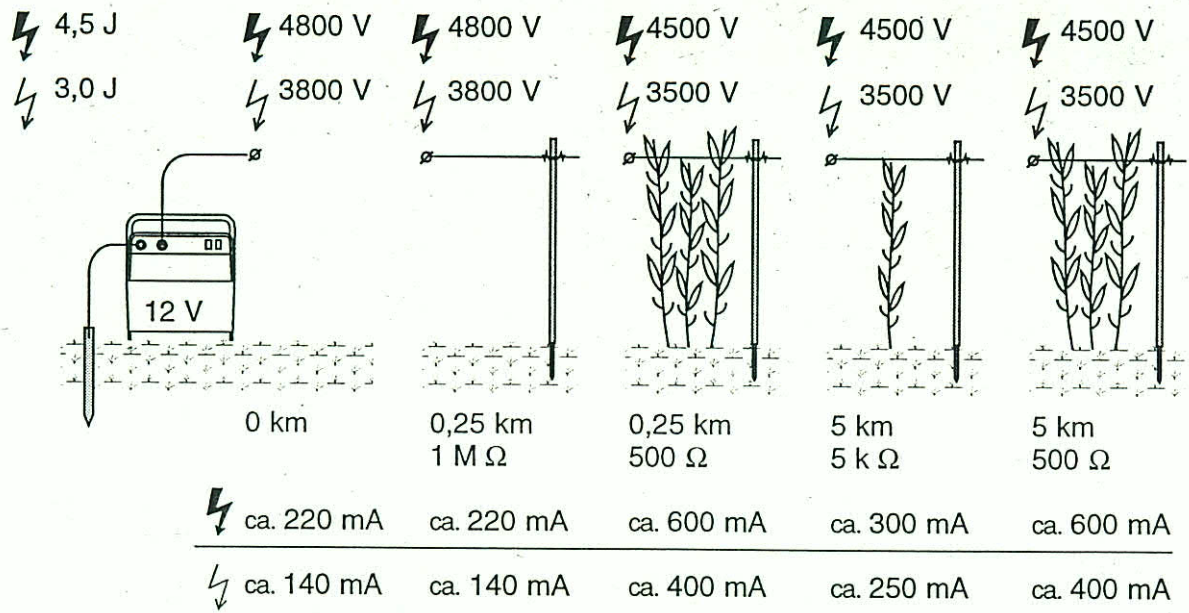

Weight (without accu) : 3,6 kg

CEE: max. fence line length

