



OPERATING INSTRUCTION

PRSPRO 100 Electric Fence Energizer



2031 300th Street · Washington, IA 52353
www.premier1supplies.com
800-282-6631 · 319-653-7622

Read full instructions before use!



made in Germany
by horizont group gmbh
Animal Care



PRSPRO 100 (15W/15Ah)

Requirements:

The energizer complies with the **International Safety Standard IEC 60335-2-76 + EN 60335-2-76.**

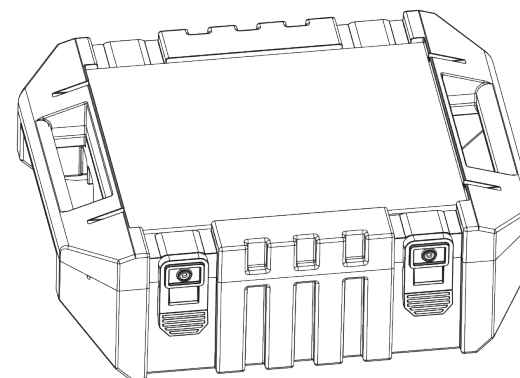

2031 300th Street · Washington, IA 52353
www.premier1supplies.com
800-282-6631 · 319-653-7622



assembled in US and Europe
horizont group gmbh
Animal Care



PRSPRO 100
Item 113800

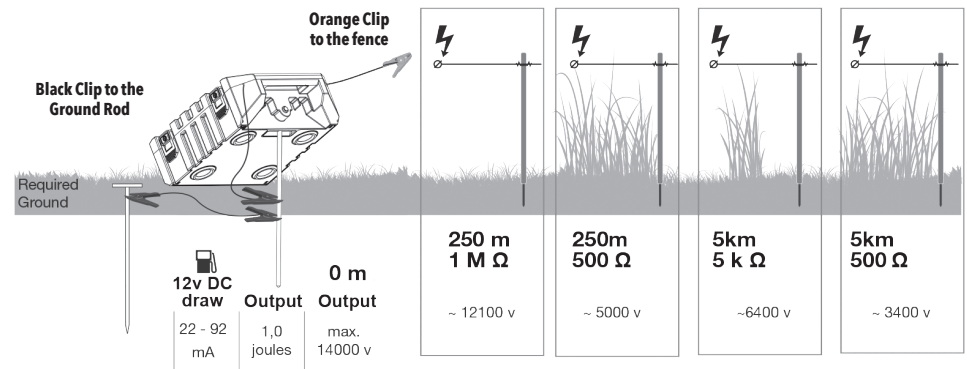
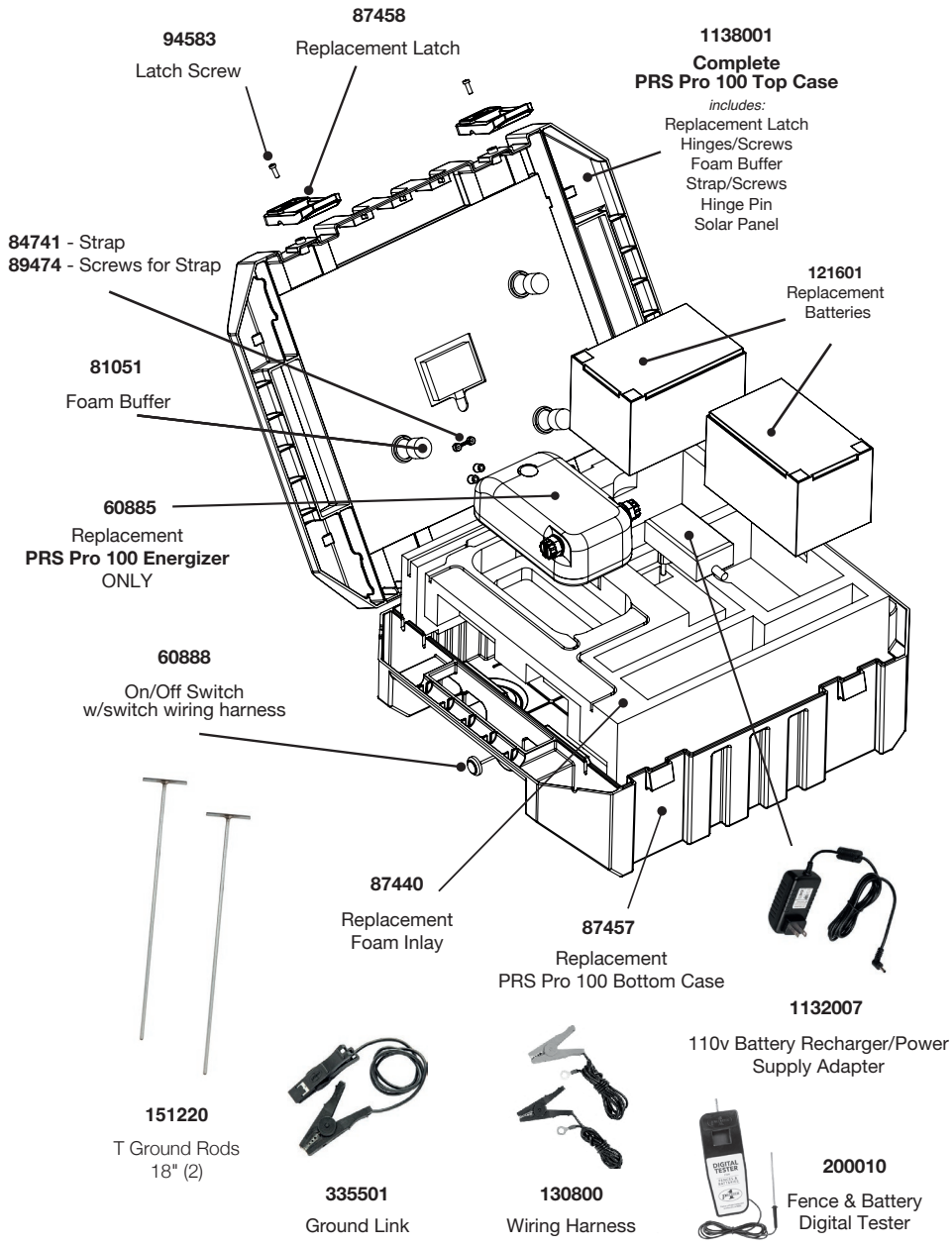

MAX. FENCE LINE LENGTH

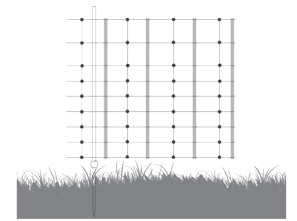

PRS Pro 100 = 5-8 Rolls

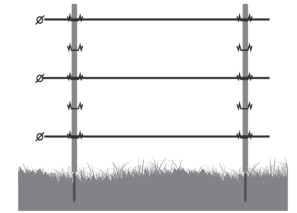

PRS Pro 100 = 1,5 mile

WARRANTY:

3-year warranty for energizers and solar panels cover lightning damage and defective parts or workmanship. Should an energizer fail, we will replace the unit, bill you for the cost to do so, then reimburse you for warranted expenses after we have examined the failed unit. Misuse and flood damage are not covered.

30-day warranty for all batteries.

READ FOR SPECIAL APPLICATIONS:

- Of electric fences in pastures: Train livestock to Power Fencing prior to entry into pastures. Allow livestock to approach a Power Fence for the first time without stress.
- Of electric fences in zoos and game reserves: The mounting of such installations may only be carried out by trained specialist, a mechanical barrier must be provided which separates the electric fence from visitors.
- Of Game Fencing: Power Fencing has been used widely throughout the world for game animals, deer, bears, elk and elephant. Power Fences are a psychological barrier and should not be considered a complete physical barrier fence. With any Power Fence occasional animal penetration may occur (as with any other type of fence). It is important for game fencing to have power on the fence the same day as the fence is constructed. Animals investigating the new obstruction will be shocked and will relate the shock to the new obstruction. If no power is on the fence and animals learn to walk through the fencing system with no electric shock, this causes major problems later on since they will not relate the electric shock to the fence after the power is turned on. A Power Fence is not recommended for animals under hunting pressure. For specific questions on game fencing contact your dealer.
- Of Bird Deterrent: Where the Energizer is used to supply a system of conductors used for deterring birds from roosting on buildings, no conductor should be connected to earth. A switch should be installed to provide means of isolating the Energizer from all poles of the supply and clear warning signs should be fitted at every point where persons may have ready access to the conductors. The notice should bear the words "LIVE WIRES" in block letters not less than 13mm (½" high). The letters should be red on a white background. Each notice should be at least 62mm x 50mm (2½" x 2").

SAFETY GUIDELINES ELECTRIC ANIMAL FENCES—TO REDUCE RISK AND LIABILITY

REMEMBER:

Never touch an electric fence wire with your head or upper torso (see photo at right). Never allow anyone else to do so. Instruct all visitors and children to never do so.

Risk and Liability Reduction Methods

1. For reasons not fully understood, contact with the spinal & head area is much worse than contact with hands, arms or legs.
2. Most experts agree that smaller energizers are safer than large ones (as long as animal control is not put at risk). So use smaller energizers on fences near children and untrained adults. To do so, change the fence design or management to reduce the need to wire contact.
3. Never connect two energizers to one wire at the same time.
4. Never energize barbed wire.
5. With high joule energizers reduce the available energy on wires near children or untrained adults with a 500 ohm resistor. (Not illustrated here.)
6. Hang warning signs on the fence at critical areas where children or untrained adults will encounter them.
7. Where practical do not energize wires less than 12 in. above the soil. Why? To allow humans that might contact a wire enough space to fall (by gravity) away from any energized wires.
8. Ensure that all energized wires are on the inside of your boundary fence (ensuring that anyone who touches them without your permission is a trespasser). For boundary fences achieve this with internal energized offset wires.
9. The shock from electric fences can panic animals who may in turn crash into fences (or people) resulting in injury to one or both. Horses have been known to rear and throw their rider resulting in injuries to both.

TO REDUCE THIS RISK:

- a. Build only non-electric fences along horse trails, around live-stock corrals and surrounding lots.
- b. Reduce the available volts and joules on fences that enclose very small areas (e.g. night enclosures) thus reducing panic and stress.

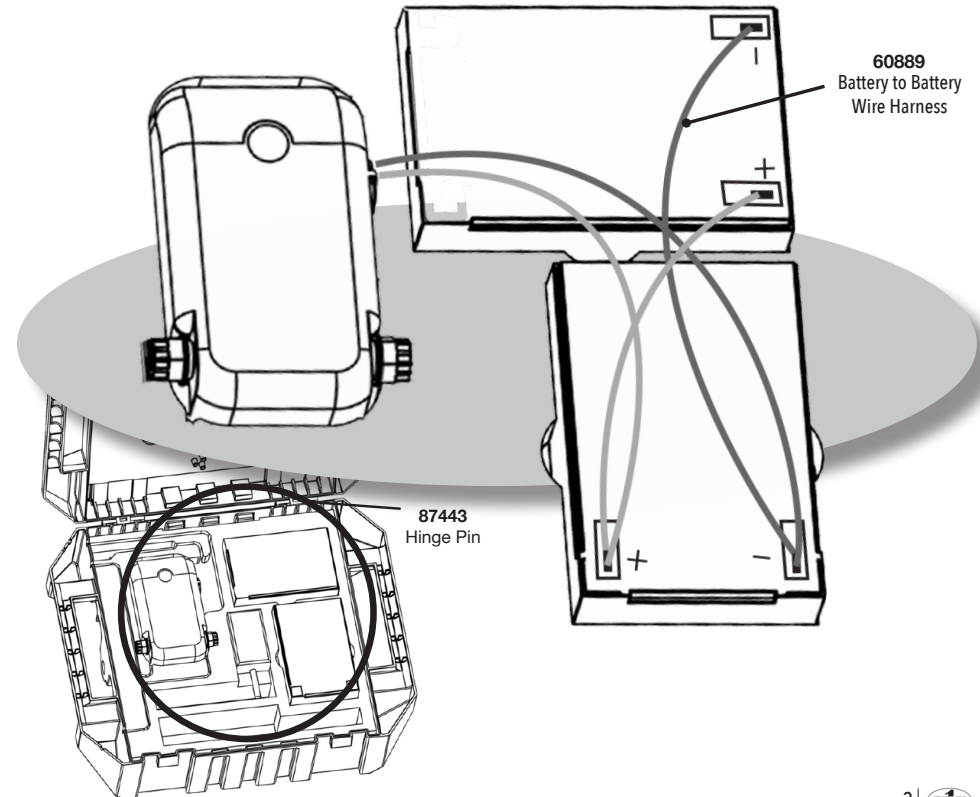
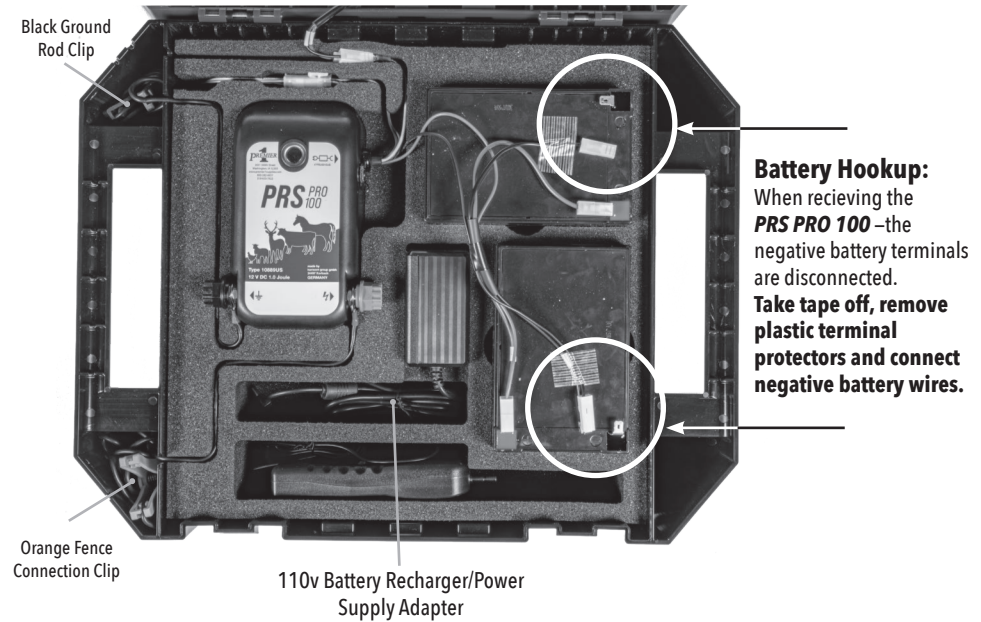

STEP 2: SETTING UP THE ENERGIZER

SAFETY GUIDELINES ELECTRIC ANIMAL FENCES CONTINUED

Fence and Ground Clips connected to the energizer inside the case are routed through two cutouts in the side of the case. When not in use or during transport, connect the clips to the tabs that are on either side of the on/off switch on the outside of the case.

CAUTION: When closing the lid, make sure the ground clip wires are routed through the slots of the case to prevent damage from pinching.

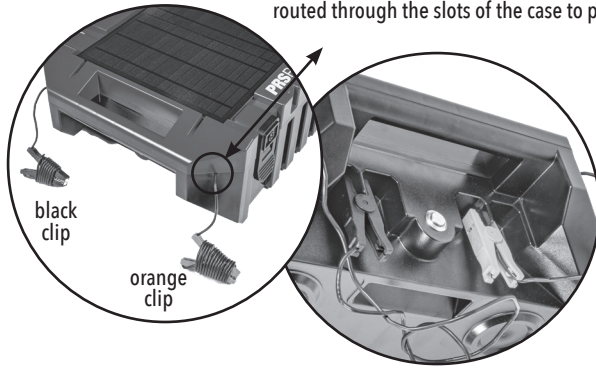

WHEN SETTING UP ENERGIZER:

1. Make sure battery negative leads are connected (see **Battery Hookup** diagram on the previous page).
2. Insert one of the T Ground Rods in the back of the energizer (perpendicular in the ground **NOT** at a slant) for support.
3. Insert the 2nd T Ground Rod at least 2 ft away and connect the two with the Ground Link (wire with 2 black clips).

HOOKING UP ENERGIZER: Energizer should be off!

1. Connect the black clip to the 1st ground rod.
2. Connect the orange clip to the fence.
3. Turn energizer on.
4. Check the voltage to ensure the fence is properly electrified before introducing animals: min of 3000v at the end of the fence.

Energizer ground system should be installed at least 30 ft away from any other grounding source.

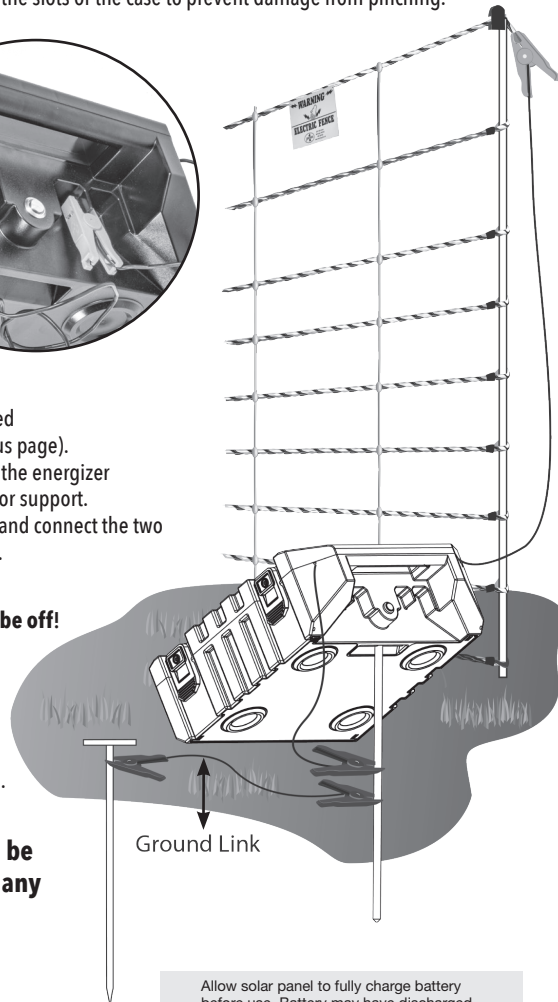

ON/OFF POWER BUTTON

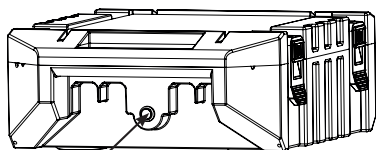

ON / OFF

Power & Control Button

CONTROL
OFF ON

BATTERY TEST

- ☐ GREEN = good battery
- ☐ GREEN = charge the battery
- ☐ RED = very low battery; charge immediately

Allow solar panel to fully charge battery before use. Battery may have discharged during storage and transport. Battery should test 12.6 volts or higher.
Make sure panel always faces due south. See diagram above and at right for proper angle. **Warning:** Do not let the energizer sit in the sun for an extended period when it is turned OFF. Why? This could damage the battery.

Crossings with overhead power lines shall be avoided wherever possible. If such a crossing cannot be avoided it shall be made underneath the power line and as nearly as possible at right angles to it.

If connecting leads and electric animal fence wires are installed near an overhead power line, the clearances shall not be less than table below.

MINIMUM CLEARANCES FROM POWER LINES FOR ELECTRICAL ANIMAL FENCES

Power line voltage (V)	Clearance (m)
≤ 1000	3 (10 ft)
>1000 and ≤ 33000	4 (13 ft)
>33000	8 (27 ft)

If connecting leads and electric animal fence wires are installed near an overhead power line, their height above the ground shall not exceed 2m (6ft). This height applies to either side of the orthogonal projection of the outermost conductors of the power line on the ground surface, for a distance of
 - 2 m for power lines operating at a nominal voltage not exceeding 1000 V;
 - 15 m for power lines operating at a nominal voltage exceeding 1000 V

Electric animal fences intended for deterring birds, household pets, containment or training animals such as cows need only be supplied from low output energizers to obtain satisfactory and safe performance.

In electrical animal fences intended for deterring birds from roosting on buildings no fence wire shall be grounded if the fence wires are not connected to metal parts. If one wire is connected with a metal part (i.e. a gutter) or a metal structure of the building these metal parts must be grounded.

A warning sign shall be fitted to every point where persons may gain ready access to the conductors.

Where an electric animal fence crosses a public pathway, a non-electrified gate shall be incorporated in the electric animal fence at that point or a crossing by means of stiles shall be provided. At any such crossing, the adjacent electrified wires shall carry warning signs. In areas of public access, use an electric fence warning sign (G6020) every 10m (33ft) to identify the electrified wire(s).

Any part of an electric animal fence that is installed along a public road or pathway shall be identified at frequent intervals by warning signs securely fastened to the fence posts or firmly clamped to the fence wires.

The background color of both sides of the warning sign shall be yellow. The inscription on the sign shall be black and shall say **WARNING!**

The inscription shall be indelible, inscribed on both sides of the warning sign and have a height of at least 25 mm (10 inch). Ensure that all mains-operated, ancillary equipment connected to the electric animal fence circuit provides a degree of isolation between the fence circuit and the supply mains equivalent to that provided by the energizer.

NOTE: Ancillary equipment that complies with the requirements relating to isolation between the fence circuit and the supply mains in Clauses 14, 16 and 29 of the standard for the electric fence energizer is considered to provide an adequate level of isolation. Protection from the weather shall be provided for the ancillary equipment unless this equipment is certified by the manufacturer as being suitable for use outdoors, and is of a type with a minimum degree of protection IPX4.

- Do not place combustible materials near the fence or Energizer connections. In times of extreme fire risk, disconnect energizer.
- If there is a danger of over-flooding, the energizer must be turned off.
- Help to avoid any misuse of the energizer by:
 - Observing the printing*
 - Secure the energizer against un-allowed access (e.g. anti-theft or anti-children equipment) if the location make this necessary*
- Check your local ordinance for specific regulations.
- Read International Safety Standard IEC 60335-2-76 + EN 60335-2-76

Electric animal fences and their ancillary equipment shall be installed, operated and maintained in a manner that minimizes danger to persons, animals or their surroundings.

WARNING: Do not touch the fence with the head, mouth, neck or torso. Do not climb over, through or under a multi-wire electric fence. Use a gate or a specially designed crossing point.

Electric animal fence constructions that are likely to lead to the entanglement of animals or persons shall be avoided.

An electric animal fence shall not be supplied from two separate energizers or from independent fence circuits of the same energizer.

For any two separate electric animal fences, each supplied from a separate energizer independently timed, the distance between the wires of the two electric animal fences shall be at least 2,5 m (8,3 ft). If this gap is to be closed, this shall be effected by means of electrically non conductive material or an isolated metal barrier. Barbed wire or razor wire shall not be electrified by an energizer.

A non-electrified fence incorporating barbed wire or razor wire may be used to support one or more off-set electrified wires of an electric animal fence. The supporting devices for the electrified wires shall be constructed so as to ensure that these wires are positioned at a minimum distance of 150 mm from the vertical plane of the non-electrified wires. The barbed wire and razor wire shall be earthed at regular intervals.

Follow the energizer manufacturer's recommendations regarding grounding.

A distance of at least 10 m (33 ft) shall be maintained between the energizer ground and any other grounding.

Connecting leads that are run inside buildings shall be effectively insulated from the grounded structural parts of the building. This may be achieved by using insulated high voltage cable. Use this lead-out cable in buildings and where soil could corrode exposed galvanised wire. Never use household electrical cable: it is made for a maximum of 600 volts and will leak electricity.

Connecting leads that are run underground shall be run in conduit of insulating material or else insulated high voltage cable shall be used. Care must be taken to avoid damage to the connecting leads due to the effects of animal hooves or tractor wheels sinking into the ground.

Connecting leads shall not be installed in the same conduit as the mains supply wiring, communication cables or data cables.

Connecting leads and electric animal fence wires shall not cross above overhead power or communication lines.

FOR RECHARGING 12V BATTERY VIA 110V POWER SUPPLY:

Move the energizer indoors (without fence and ground connection "wiring Harness") Attach the 110v Battery Recharger/Power Supply Adapter to the energizer in the DC2.1 socket in the side of the energizer.



Recharger/ Power Supply Adapter

CONNECTING ENERGIZER TO 110V

TO USE ENERGIZER CONNECTED TO 110V:

1. Attach 110v Battery Recharger/ Power Supply Adapter.
2. Operate energizer from a 110v outlet instead of with the solar panel/battery.

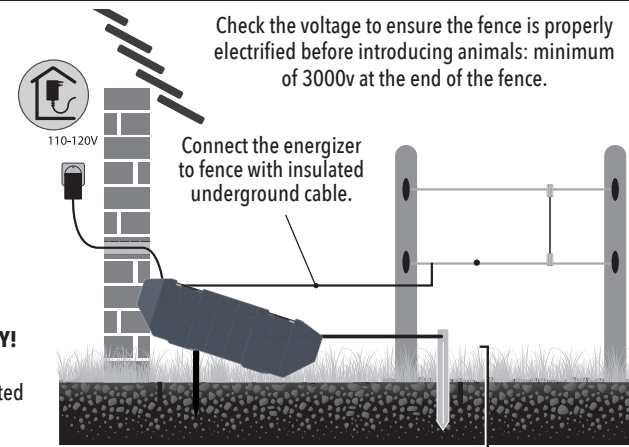

Check the voltage to ensure the fence is properly electrified before introducing animals: minimum of 3000v at the end of the fence.

Important:
INDOOR DRY LOCATIONS ONLY!
For 110v operation the 110v adapter must be installed protected from moisture.

OPTIMAL SOLAR ORIENTATION AND PLACEMENT



1. POSITION THE ENERGIZER SO THAT THE SOLAR PANEL FACES DUE SOUTH. This will allow the panel to receive the maximum amount of sunlight possible even during the low-light days of winter. Consider the sun's movement throughout the day and avoid placing the unit where it may be covered by shadows from trees, bushes or tall grass. The unit needs full, uninterrupted sunlight to operate well.

2. DETERMINE THE CORRECT TILT ANGLE FOR THE SOLAR PANEL. The sun's position above the horizon will change from season to season. As a general recommendation, an angle of 50° is optimal for the longest use in most areas of the continental USA. However, the ability of the solar panel to recharge the battery can be maximized by making angle adjustments each season.

In the far northern USA from November until February, there may not be enough hours of sunlight to fully recharge the battery. Charge the battery with the 110V recharger when the battery indicator light flashes green/red or red.
Or keep extra batteries.

3. REGULARLY REMOVE ALL DEBRIS FROM THE SOLAR PANEL. This includes grass clippings, dust (especially on gravel roads), leaves and snow as this will reduce the solar panel's ability to recharge the battery.

OPERATING INSTRUCTION FOR ELECTRIC FENCE ENERGIZER

WORKING PRINCIPLE:

The solar panel produces electric current when exposed to usable sunlight. The fence energizer requires a constant current, day and night. Thus the panel current is stored in the battery which delivers the energizer current. The solar panel might not always be capable of recharging the battery—especially in dark, grey and foggy months (i.e. October-February) **Tip: Recharge the battery externally as needed.**

STORAGE, RECHARGE, MOUNTING AND CONNECTIONS:

When not in use, ensure the battery stays charged. You can charge the battery in the sun or with the included 110V charging unit. Stop charging when the battery indicator light flashes GREEN, or reaches 12.6V – 13.4V. Do not overcharge the battery.

When the energizer is not being used, store the unit indoors at room temperature and out of the sun. Batteries don't work well when they're left discharged, or at a low charge, for long periods of time. Periodically recharge the battery so that it does not discharge below 60%.

WARNING: Do not let the energizer sit in the sun for an extended period when it is turned OFF. Why? This could damage the battery.

BATTERY CONNECTION:

Attach negative battery lead to battery. Make sure all other connections are tight.

ENERGIZER CONNECTION (using the enclosed wiring harness).

HOW TO USE:

Open the energizer lid and connect the wires to the battery as indicated on the enclosed sticker. Remove the T Ground Rod from inside the box. Drive in the ground. Then slide the energizer onto top of T Ground Rod. Use the wiring harness to connect the energizer to the ground stake and fence.

CAUTION:

The energizer should only be opened or repaired by qualified personnel, to reduce the risk of electric shock!

BATTERY VOLTAGE

Start energizer using **On/Off Button**. After a few seconds a LED control flashes to indicate battery voltage. If there is no flashing, either the battery is depleted, connections aren't correct or there is a fault in the energizer. **To test the battery:** First disconnect all wires from the battery. Use a 12 volt tester to determine the available voltage.

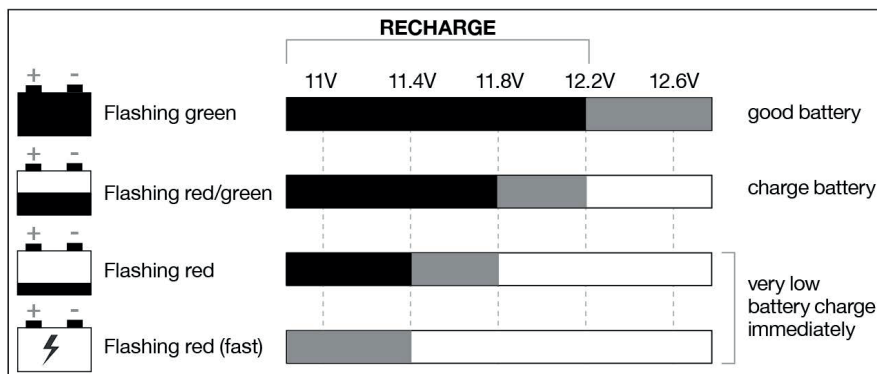

BATTERY INDICATION:

Test battery only at daybreak. If the battery test light is flashing red/green, recharge the battery. The battery should never fall below a 20% charge (continuous red light). If this happens, permanent damage may occur to the battery. Please note, that these values can vary due to the dependence of the battery itself, the age of the battery, the temperature (capacity) and mesuring deviation (tension).

GROUNDING:

For a faultless operation and to obtain the optimal output, good grounding is essential. Therefore grounding must be made in a moist location. An additional or deeper ground rod may improve grounding. The distance between the system earth (grounding) and other earth systems (e.g. telephone, mains power, anti-lightning or other earth systems of another energizers) should be at least 30ft.

DUTY TO THE PUBLIC:

Safe electric fence construction - read and respect in conjunction with B. SAFETY HINTS ELECTRICAL ANIMAL FENCES. Electric fence can be hazardous when there is a risk of entrapment or entanglement, or other hazards exist. Serious injury or death may result. Take all steps to avoid the risk of entrapment or entanglement. Fasten warning signs to electric fence posts or wires at frequent intervals along any public roads or pathways. Incorporate a non-electrified gate or stile where an electric animal fence crosses a public pathway and fasten warning signs to fence posts or wires adjacent to the crossing

SAFETY GUIDELINES ELECTRIC ANIMAL FENCES

PRINCIPLES AND LIMITATIONS OF ELECTRIC FENCING FOR ANIMALS:

An electric fence consists of an energizer and a connected fence where the energizer feeds electric pulse into the fence. The electric animal fence represents a "psychological barrier" for the animals; it keeps animals inside or outside a certain area, it can also be used to train a certain behaviour (e.g. cow trainer in the stable). The electric security fence is used for security purposes that comprise an electric fence and a physical barrier electrically isolated from the electric fence. No electric or mechanical fence can guarantee a 100% effective solution in protecting or containing your animals. The effectiveness of an electric fence may vary upon the unique local conditions within which the fence is installed. A suitable combination of products together with competent installation will ensure the best results. On occasion a determined animal may overcome the most rigid of me-mechanical fences or the most comprehensive electric fence system. **For this reason the seller gives no assurance that the fence system is 100% safe against outbreak.** A well installed electric fence can offer a high level of security when compared to a mechanical fence, as the psychological barrier an electric shock can represent will deter the animal from finding a way to circumnavigate the fence. Electric fences will also offer far greater level of flexibility.

WARNING FOR SAFE ELECTRIC ANIMAL FENCES:

- This appliance is not intended for use by persons (including children) with reduced physical, sensory or mental capabilities, or lack of experience and knowledge, unless they have been given supervision or instruction concerning use of the appliance by a person responsible for their safety. Children should be supervised to ensure that they do not play with the appliance.
- Never touch an electric fence wire with your head, mouth, neck or torso. Never allow anyone else to do so. Instruct all visitors and children to never do so. Do not climb over, through or under a multi-wire electric fence. Use a gate or a specially designed crossing point.
- To avoid any risks with head, mouth, neck or torso contacts use only smaller energizers or the lower output of a stronger energizer on fences near children and untrained adults. With high joule energizers reduce the available energy on wires near children or untrained adults with a 500 ohm resistor. To do so, change the fence design or management to reduce the weed to wire contact, if necessary.
- Keep a distance of at least 2,5 m (8,3 ft) with the electric fence to all metallic parts i.e. to water-pipes and troughs especially if persons can be in the vicinity.
- Do not connect simultaneously to a fence and to any other device such as a cattle trainer or a poultry trainer. Otherwise, lightning striking your fence will be conducted to all other devices.