

Betriebsanleitung

Instruction manual

Mode d'emploi

Manual de Instrucciones

Instruksjonsbok

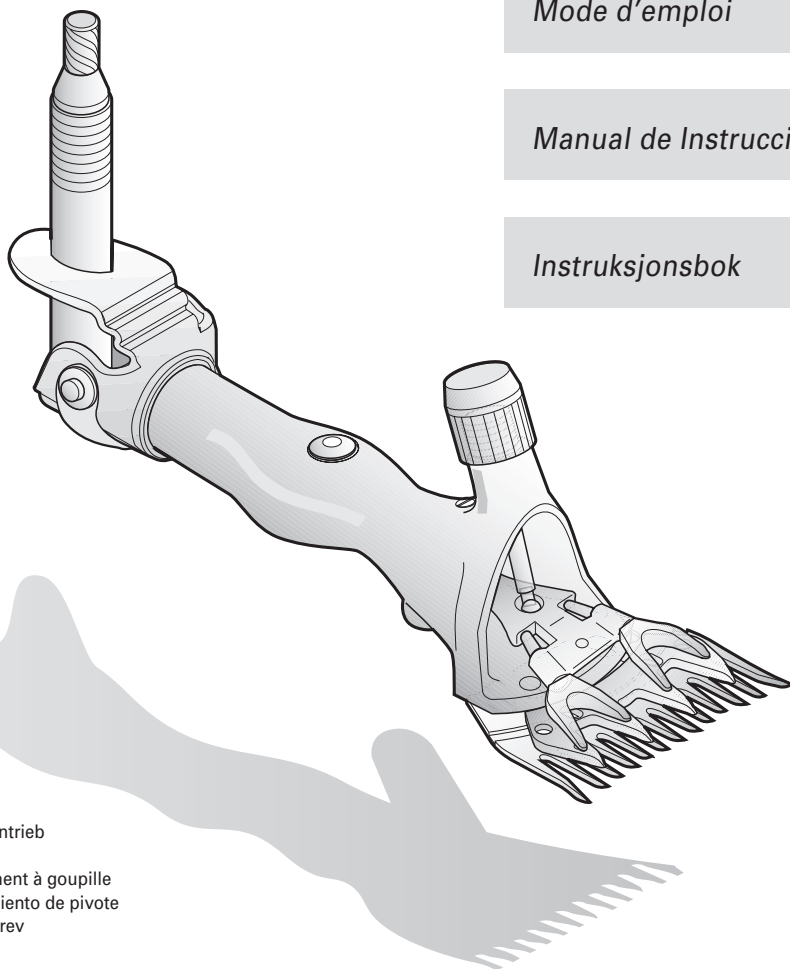

Exzenterantrieb
Pin-drive
Entraînement à goupille
Accionamiento de pivote
Eksenterdrev

Schneckenantrieb
Worm-drive
Entraînement à vis-sans-fin
Accionamiento por tornillo sinfín
Snekkedrev

Contents

1 Proper Use

- 1.1 Overall View / Controls
- 1.2 Intended Use
- 1.3 Technical Data
- 1.4 Equipment Items

2 Safety Regulations

- 2.1 Introduction
- 2.2 Symbols and Warning Signs
- 2.3 Proper Use
- 2.4 Safety Principles
 - 2.4.1 Drive Connections
 - 2.4.2 Servicing and Checking Requirements
 - 2.4.3 Noise Emission / Personal Protective Equipment
 - 2.4.4 Other Dangers
- 2.5 Essential Operator Skills

3 Putting into Operation

- 3.1 Controls and Operation Notes
- 3.2 Shearing Adjustment using the Tension Nut
- 3.3 Lubrication

4 Servicing

- 4.1 Cleaning
- 4.2 Fitting the Shearing Blade
- 4.3 Resharpener the Shearing Blades
- 4.4 Storing

5 Maintenance & Repairs

- 5.1 Introduction
- 5.2 Maintenance
- 5.3 Repair Kits
- 5.4 Malfunction List
- 5.5 How to

6 Environmental Protection and Disposal

- 6.1 Introduction
- 6.2 Material Categories

7 Contact Addresses

Illustrations: at the end of the instructions

1 Proper Use

1.1 Overall View / Controls

Component Names



Illustr. 0

Pos	Description	Total	Pos	Description	Total
1	Barrel ICON	1x	21	Back joint cap	2x
2	Centre post	1x	22	Back joint spring	1x
3	Locknut	1x	23	Inner back joint	1x
4	Comb screw	2x	24	Outer back joint	1x
5	Crankshaft	1x	25	Ball bearing	2x
6	Ball	1x	26	Cog Z14	2x
7	Safety screw	1x	27	Drive shaft ICON PIN-Drive	(1x)
8	Oil hole cap	1x	28	Tapered pin Ø3 x 12 mm	1x
9	Tension nut bushing screw	1x	29	Drive shaft ICON WORM-drive	1x
10	Retaining ring	1x	30	Chicken feet retaining spring	1x
11	Tension pin	1x	31	Pan-head screw M4 x 5	1x
12	Tension sleeve upper	1x	32	Centre post cup	1x
13	Tension nut	1x	33	Fork body	1x
14	Distance washer	1x	34	Tension pin retaining spring	1x
15	Ball bearing	1x	35	Tension pin cup	1x
16	Spring washer	1x	36	Chicken feet L+R (pair)	1x
17	Gliding bush	1x	37	Fork body assembly complete	(1x)
18	Retaining ring JV 27 x 1.2 Typ J	1x	38	Ferrule Ø22 x 180 mm solid-drive	(1x)
19	Seal	1x	38	Ferrule Ø22 x 160 mm flex-drive	(1x)
20	Back joint cover	1x			

1.2 Intended Use

The (machine) is intended exclusively for use on sheep and goats, as well as llamas, alpacas and other members of the camel family.

Other uses, in particular using the machine on people, are expressly prohibited.

1.3 Technical Data

Designation:	Mechanical Shearing Handpiece
Model:	"ICON"
RPM _{max} :	3500 U/Min.
Dimensions (B/H/L):	approx. 65mm x 95mm x 320mm
Max. Ambient Temperature:	0°C - 40°C
Max. Air Humidity:	10% - 90% (relative)
Noise Emission (L _{pA}):	>70 dB(A) (EN 50144-1/02.96 & EN ISO 3744/11.95)
Acceleration (a _{hW}):	> 2,5 m/sec ² (EN 28662-1/01.93)

We reserve the right to adopt technical changes and improvements.

1.4 Equipment Items

- 1 Shearing Handpiece (machine)
- 1 Special Screwdriver
- 1 Operating Instructions

Options:

- Various shearing combs and cutters
- Special comb cleaning brush
- Special lubricating oil
- Post Guide

2 Safety Regulations

2.1 Introduction

This Section describes the mandatory safety regulations which must be observed when using the machine.

All persons undertaking work on or with the machine have an obligation to read the operation instructions.

The operating instructions must be kept safely and accessible at all times.

2.2 Symbols and Warning Signs

Various symbols are used in the operating instructions. They refer to potential dangers or point to technical information, the non-observance of which will lead to personal injury, damage to objects or inefficient operation.

Danger Symbols

Warning



indicates a potentially dangerous situation. If preventive action is not taken, death or very serious injury could result.



Caution

indicates a potentially dangerous situation. If preventive action is not taken, the consequences could be slight or minor injuries.

Information Symbols



Note

Note, non-compliance with which can lead to operating malfunctions or damage.



Pictorial Note

This symbol, together with its number, refers to the relevant illustration at the end of the instructions.

2.3 Proper Use

The use which the machine is intended for, is described in Section 1.2.

The following applies to safe operation:

The details at Section 1.3, "Technical Data", count as mandatory operating limits and ratings.

Shearing other animals, in particular dangerous animals such as beasts of prey and the like, counts as misuse. This could lead to circumstances dangerous to life and limb.

2.4 Safety Principles

2.4.1 Drive Connections



Only connect the machine up to undamaged, inspected shearing drive shafts & motors (shearing plants). Damaged shafts or motors can cause lock up which can cause serious injury. Defective installations can cause an electric shock or a short circuit.



Illustr. 1

Make sure to use the correct type of drive coupling, i.e. only connect a worm-drive type handpiece to a worm-drive type shearing drive (Illustration 1, Item 1) and a pin-drive handpiece to a pin-drive shearing drive (Illustration 1, Item 2). Do not mix the two systems as it can cause malfunction and unexpected behaviour of the whole system.

Servicing and cleaning must only be carried out when the machine is removed from the drive (shearing plants).

Never leave the machine unsupervised when connected to a shearing drive. Keep children away from the working area and store the machine out of their reach.

2.4.2 Servicing and Checking Requirements

Only operate the machine if it is undamaged and in a proper condition. Any defects to the housing (barrel) or the drive shaft connection should be rectified by a repair or service agent.

2.4.3 Noise Emission / Personal Protective Equipment

Wear Ear Protectors !



Typical sound emission when working are >70 dB(A). We recommend that ear protectors should always be worn when working.



Wear Protective Goggles and Gloves !

For your personal protection we recommend that you wear protective goggles and gloves.



Personal protective equipment is to be provided by the operator.

2.4.4 Other Dangers

Should evidence of dangers or potential dangers, not directly related to the shearing of animals, occur during operation, we would ask you to inform us. This also applies to dangerous technical deficiencies.

2.5 Essential Operator Skills

Operating the machine safely makes only small demands of the operator. However, it is essential that they are observed and carried out.

- The operator must be experienced in handling the animals to be shorn.
- The operator must have read and understood the instructions or have been instructed by an expert in the machine's use and have had the potential dangers explained.

Children are not permitted to operate the machine.

3 Putting into Operation

3.1 Controls and Operation Notes



There are dangers inherent in the improper use of mechanical equipment, especially stock-breeding equipment! Therefore, before using the machine, you should observe the following accident-prevention measures:

- Observe the advisory notes listed at 2.4.1 (drive connections).
- Avoid all contact with the moving shearing blades (comb & cutter).
- Even when the shearing drive (shearing plant) is switched off, do not handle the area of the shearing blades as long as the machine is connected to the shearing drive. Always disconnect the machine from the shearing drive first when working on the shearing blades/machine.
- Never shear wet animals. Wet wool may enter the machine body (barrel) and cause lock up.
- Generally, never plunge the clipper and clipperhead into liquids such as water, soapy water, diesel, petrol, etc. This may cause serious injury to mechanics and motor.
- Never put your handpiece in a vice, it will disfigure the barrel and the back end will become tight.
- Never attempt to interchange parts from another model/type or brand of handpiece.
- Only use original shearing blades (combs & cutters; Illustration 5). Do not use damaged shearing blades with blunt, missing or broken off teeth. Only work using sharp shearing



Illustr. 5

- blades, ground according to advisory notes listed at 4.3 (Resharpener the Shearing Blades)
- Looking out for foreign bodies (wire, wood, etc.) in the fleece and remove them before beginning to shear.
- Wear suitable work clothes. Do not wear any loose fitting clothing or items of jewellery which could get caught up in moving machine parts. We would recommend in the strongest terms that protective goggles and ear protectors are worn.
- Never insert any object into any of the machine's apertures
- Noise from the machine can worry animals. Considerable injury can be caused as a result of being kicked by an animal or being crushed by its body weight.
- Animals should only be shorn if unauthorised persons have been excluded from the shearing area.
- Only shear in well-ventilated spaces (dust) and never near objects or gases likely to explode.
- We recommend you use a comb for no longer than an hour and a cutter for no longer than 15 minutes before you change them for a sharp comb and cutter



These Safety notes must be complied with in all cases.

3.2 Shearing Adjustment using the Tension Nut

Before putting into operation, make adjustments as follows:

Before Shearing:

With the machine disconnected from the shearing drive: ensure that the Yoke's carrier (chicken feet) cone pins mesh precisely into the positioning holes in the cutter (Illustration 2, Item 2). Tighten the tension nut until resistance is first noticeable (Illustration 2, Item 1). Then tighten the tension nut a further 1/4 turn.



Illustr. 2, 3

Connect the handpiece to the shearing drive (observe advisory notes listed at 2.4.1) and start operating the shearing drive motor. Slacken off the tension nut (Illustration 3) until the shearing blades exert almost no more contact pressure (noise level rises).



Caution! If the tension is slackened off too much, the cutter can fly off causing injury.

Now tighten the tension nut slowly until the noise level becomes muffled and some resistance is detectable as you tighten the tension nut. The pressure should now be correctly set. Begin shearing. If it still does not cut properly, you will have to add a little more tension.

During Shearing

Provided the shearing blades are properly sharpened (ground) the shearing system works with much less pressure having to be applied than with traditional shearing machines. Care should be taken, therefore, to ensure that the blade tension is not set too high. Too high tension causes more friction and reduces the life expectancy of the shearing handpiece as well as the shearing blades. Slightly adjust the blade tension from time to time during shearing (max. 1/4 turn).

Hair may collect between the shearing blades, if the tension nut is insufficiently tightened at the start of shearing. This will have an adverse effect on further shearing progress or make it quite impossible. If this happens, the shearing blades must be disassembled, cleaned, oiled and re-fitted as described at 4.2 (Fitting the Shearing Blades)

3.3 Lubrication



Illustr. 4

Before and During Shearing

A thin layer of oil on the cutter and the comb plate (Illustration 4, Item 4) is essential for good shearing results and so as to increase the life of the machine and its shearing blades. All other moving parts must also be well oiled (Illustration 4, Item 3) .

Only use our special clipper oil or a paraffin oil meeting the ISO VG 15 specification. This oil is non-toxic and produces no irritation on contact with the skin or the mucous membranes. This paraffin oil degrades to some 20% after 21 days (CEC-L-33-T-82).

You cannot over oil ! The more often you oil, the cooler it will run and the longer it will last. Especially if you are shearing llamas, alpacas or other camelides, even more frequent oiling of comb and cutter may be needed.

Always oil the machine before use, and at least at every cutter change.

Oil the following parts

- Before you assemble the blades to the hand piece turn the handpiece upside down (Illustration 4, Item 1) and run oil into the centre post cup through the hole illustrated.
- Oil the tension sleeve or top of tension pin (Illustration 4, Item 2).
- Turn it back over and oil tension pin cup (Illustration 4, Item 3).
- Wet the cogs with oil.
- Oil down the ferrule to lubricate the outer back half joint and the pin or worm drive.
- Oil the ball through the hole in the top of the barrel.
- Oil the cutter and comb when set (Illustration 4, Item 4).

Do not put oil or grease between the tension nut and the tension sleeve as this will cause loss of tension.

Grease

Once a week remove, clean and regrease the following parts:

- Yoke's carrier (chicken feet) - Remove the comb and cutter, turn the yoke's carrier at 90 degrees to the fork and pull them out using a pair of pliers. Clean them and the locating holes in the fork and apply a small amount of grease on the yoke's carrier shank and replace it making sure they twist freely in the fork when replaced. If they don't, remove and clean more thoroughly.
- Back Joint Caps – Remove the back joint spring, take off the caps and clean out any old grease and dirt. Apply a small amount of grease in the cap and reassemble.
- Tension Sleeve – Remove the tension nut, tension sleeve and tension pin. Remove all the grease from inside the tension sleeve and from the tension pin. Apply a good amount of grease to the inside of the tension sleeve and replace it, remember to remove all grease from the outside of the tension sleeve before replacing the tension nut.

Bearings

The shearing handpiece is fitted with bearings which are sealed and will never need oiling or greasing.

4 Servicing

Before starting any servicing work, disconnect the handpiece from the shearing drive.

4.1 Cleaning

After shearing, remove all oil from the machine by rubbing it down with a dry cloth and carefully clean the outside of the shearing handpiece and the shearing blades with a dry brush. Then oil the parts to prevent rusting. Even the smallest rust spots on the blades can adversely affect shearing or make it completely impossible.

4.2 Fitting the Shearing Blades



Illustr. 5, 3, 6

A pair of shearing blades consist of a comb plate (Illustration 5, Item 2) and an cutter (Illustration 5, Item 1). When fitting the blades care should be taken to ensure that the correct surfaces come to rest against each other. The blades are fitted as follows:

Loosen the tension nut (Illustration 3) and place the machine on a hard surface so that the comb blade fixing screws lie uppermost. Slacken off the screws (Illustration 6) and remove both the old shearing blades.

Ensure that the new shearing blades are clean. Particular care should be taken to ensure that the ground surface are free of dirt; if not, even newly ground shearing blades will not shear satisfactorily.



Illustr. 2, 7, 8

Place the new cutter in the yoke's carrier (chicken feet) cones (Illustration 7 and 2, Item 2) and push the new comb plate between the loosened screws (Illustration 8). Now tighten the comb blade fixing screws until you can just move the new comb plate sideways by hand.

Now turn the machine over so that the tension nut is against uppermost.



Illustr. 9, 2

What is now important is that you rest the blades against each other in such a way that the ground surface of the comb plate projects approx. 1.5 - 2.0 mm beyond the tips of the cutter (Illustration 9) at the same time all sharp corners of the cutter indicated at (c) must be within the indicated area (b)

Once you have adjusted the shearing blades, set the position of the comb plate and tighten up the comb blade fixing screws.

Check that the shearing blades have been correctly fitted and that the pressure yoke's carrier (chicken feet) cones (Illustration 2, Item 2) are situated in the holes provided in the cutter. Now tighten up the tension nut until the cutter is pressed against the comb plate and you can feel a slight resistance.

4.3 Resharpener the Shearing Blades

Only work with sharp shearing blades. Replace blunt blades or those with missing teeth. Proper resharpener can only be done with a special shearing blade grinder and by a trained technician or experienced Shearer. For correct shearing blade grinding technique, please follow the instructions which comes with every Heiniger shearing blade grinder.



4.4 Storing

Only store the shearing handpiece in a dry place. Do not connect it to a shearing drive if you suspect any liquid has got into it. There is then the risk of a corroded and therefore seized drive mechanism which, if you try to run the handpiece, can cause injury.



Illustr. 23

Make it a habit to store the machine between use, store it well-cleaned, oiled and with tension slackened off, in a clean, dry place, out of the reach of children.

5 Maintenance & Repairs

This product has been developed and assembled using the best individual components available. It is designed to give longevity and high performance. If spare parts are used during the life of this product, please ensure that they are genuine Heiniger parts. Failure to use genuine Heiniger spares may reduce the performance of this precision engineered product and will void any warranty claim.

5.1 Introduction

Always contact an authorised service centre if you are unsure how to rectify the problem and in the event of malfunctions not contained in these instructions

Details of authorised service centres are to be found at the end in the „7 Contact Addresses“ section.

5.2 Maintenance

It is impossible for us to say how often you should replace parts, as wear factors vary from country to country and shed to shed, however, the components are manufactured from the highest quality metals that will enhance the life expectancy of your handpiece.

5.3 Repair Kits

Three repair kits are available. It is advisable to fit complete repair kits and not replace individual parts when carrying out a service, this will ensure the smooth and true running of your shearing handpiece.

Repair kits consists of the following parts:

Short Replacement Kit	Long Replacement Kit	Bearing Replacement Kit
<ul style="list-style-type: none"> • tension sleeve • tension pin • tension pin cup • tension pin retaining spring • centre post • centre post cup 	<ul style="list-style-type: none"> • tension sleeve • tension pin • tension pin cup • tension pin retaining spring • centre post • centre post cup • centre post lock nut • 2 x cogs • ball 	<ul style="list-style-type: none"> • Front bearing • Back half joint bearing • seal • wave washer • circlip • distance washer

5.4 Malfunction List

Actions to be taken to rectify malfunctions are indicated in the „Rectification“ column of the malfunction list. Those rectification notes printed on a dark background may only be carried out by a trained person or an authorised service centre.

MALFUNCTION	CAUSE	RECTIFICATION
Handpiece runs hot.	Firstly, find out where exactly on the handpiece the heat is coming from. Let it cool down. Start again and attempt to locate the original heat source.	
Heat from front region in general.	Is there sand and/or grit inside the front of the barrel.	With comb and cutter in place and a firm grip on your handpiece, put your thumb over the oil hole and fill the barrel with oil from the front while the handpiece is running. Whilst still running turn it upside down and drain the oil out.
	Check that your comb and cutter are sharp and not over tensioned.	Resharpen. Then use less tension.
Heat on thumb or forefinger.	Centre post has dirt between it and the centre post cup.	Remove the cutter, turn the handpiece upside down and oil the centre post cup liberally.
	Centre post & cup are well worn.	Fit short repair kit.
Hot tension nut.	Top of tension pin and inside tension sleeve.	First clean out the tension sleeve and clean the tension pin. Regrease and try again.
	Top of the tension pin is worn.	Replace tension pin and sleeve.
Hot on ring finger or middle of handpiece.	Have you put the ball on the wrong way around ? The flat side goes to the crank head.	Remove and turn around.
	Wool build up between ball and crank head around the crank pin.	Remove wool.
	Front bearings is running hot, probably caused by too much tension or blunt comb and cutter.	Use less tension or resharpen comb and cutter.
	Has the crank got a lot of movement up and down inside the bearing ?	Replace bearings.

MALFUNCTION	CAUSE	RECTIFICATION
Hot on little finger or at the back of the handpiece.	Cogs may be dry.	Oil more regularly.
	Cogs may be worn.	Always replace special cogs in pairs. It is essential to use identical special cogs.
	Sideways movement between inner and outer back half joints causing the cogs to run untrue.	Replace caps and back joint spring.
	Back bearing running hot due to too much tension, comb and cutter are blunt.	Resharpen comb and cutter.
	Bearing failure.	Replace bearings.
Loss of tension between comb and cutter.	Grease or oil between the tension sleeve and tension nut.	Clean the sleeve and inside the tension nut.
	Worn or no tension retaining spring.	Replace tension retaining spring. Make sure the end without the 90 degree bend points in the clockwise direction.
	Worn tension pin, sleeve and cup.	Replace all three parts.
	Has your tension nut bushing screw come loose ?	Remove it, clean it and the thread inside the barrel.
Loss of cut.	Firstly ask other shearers in the shed if they have the same problem. If they do, maybe it's not your handpiece.	
	Check your comb and cutters are sharp.	Sharpen your gear twice to make sure.
	Check your cutters are ground flat with a burr on the tips.	
	have you changed grinder ?	It takes 3 good grinds to reshape your combs to a new position on the disc or when using a new disc.
	Are you using very thin combs and the fork is hitting the comb screws ?	Grind down comb screw thread.
	Has your post shifted.	Reset with post guide or reset to original clock mark.
	Worn parts. Tension -pin, -cup and -sleeve.	Fit short repair kit.
	Cracked comb screws (too much heal grind on combs).	Replace comb screws.

MALFUNCTION	CAUSE	RECTIFICATION
	Are you using thin cutter with chicken feet pins reaching through the cutter and hitting the comb ?	Use thicker cutters or file a small amount off your pins.
Tight back end.	Wool or grease build up under the back joint cover.	Remove and clean thoroughly.
	Dirt between the inner back half joint and the bush.	Remove the back joint, clean the back joint and inside the bush with a rag moist with solvent. Replace the seal, recoil and reassemble.
	Have you put your barrel in a vice ?	Buy a new one.
	Have you reassembled the handpiece using an old circlip?	Replace with new circlip.
	Have you over compressed circlip when fitting ?	Replace with new circlip.
Abnormal vibration or runs rough.	Firstly locate where the problems is in your handpiece, also try it on another shearing drive to see if the problem is still present.	
Vibration from front.	Check chicken feet are a good fit inside fork body.	Replace chicken feet.
	Is your comb tight on the comb bed ?	Tighten combs screws.
	Has your post come loose ?	Reset and tighten.
	Are you using thin combs and the fork is hitting the combscrews ?	Grind down comb screw thread.
	Have you had a comb and cutter lock up ? Clean and check fork thoroughly for cracks.	If cracks are present, replace it immediately.
	Cracked comb screws (from too much heal grind).	Replace comb screws.
	Check chicken feet pins are not over worm where they fit into cutter.	Replace chicken feet.
Vibration from middle.	Check the ball is a good fit on the crank shaft.	Replace ball.

MALFUNCTION	CAUSE	RECTIFICATION
	Check the ball race in the fork is smooth.	Replace fork body.
	Check the front bearing for wear.	Replace bearing.
	Check the fork is not hitting the crank shaft head because the post is not correctly set.	Reset post.
	Has your handpiece locked up and bent the crank shaft?	Replace the crank shaft.
Vibration from back end.	Check the ferrule is not sloppy inside the short tube.	Change the short tube and the ferrule.
	Check you have no movement between the back half joints.	Replace caps and back joint spring.
	Check your cogs are in good condition.	Always replace special cogs in pairs. It is essential to use identical special cogs.
	Check the inner back half joint is a good fit inside the bush with no sideways movement.	Replace the bush first, if it is still sloppy replace the inner back half joint (always replace the seal).
	Check the bearings in the inner and outer back half joints.	Replace if worn.



5.5 How to

Note: This Section is for experts only. Do not follow this instructions if you are not a trained technician or experienced Shearer with good knowledge of mechanics. Wrong or unprofessional repair and maintenance of the handpiece can cause malfunctions which lead to serious injury, damage and/or reduced life expectancy of your shearing handpiece. Warranty will be void if unprofessional repair or maintenance has been carried out.

Remove Fork

Unscrew tension nut and remove tension sleeve and tension pin, unscrew fork safety screw. Fork may now be removed. It is not necessary to remove the centre post when removing the fork. Reassemble in the opposite order.

Fitting a new ball

Remove fork and ball, place new ball on the crank pin using a piece of wire or a pencil with the flat side of the ball pointing to the crankhead or rear of the handpiece.

Replacing the tension pin cup

Remove fork, punch out the old tension pin cup. Place the new tension pin retaining spring on to the tension pin cup before replacing it into the fork, tap the cup into the fork making sure the slope on the top of the cup faces directly towards the ball race or the back of the fork.

Remove and replace Back Joint

Remove comb and cutter and screw firm tension on tension nut, put a screwdriver down through the oil hole in the top of your handpiece so it goes between the fork and barrel, remove the cog from the end of the crankshaft using a cog spanner. The back joint will now slide out off the barrel.

Reassemble Back Joint

- First clean the back joint thoroughly.
- Place your new seal (Illustration 10, Item 18) over the inner back half joint (Illustration 10, Item 23) with the two lips facing the cogs. Ensuring that the inner lip on the seal is not twisted, slide the seal half way up the inner back half joint.
- Oil the bush inside the barrel and the inner back half joint.
- Slide the back joint into the barrel until the seal is in the barrel
- Firmly push the seal into place then push the remainder of the back joint home.
- And replace the special cogs.
- Always use pairs of identical special cogs by the same part numbers for replacement.



Illustr. 10

Fitting Bearing Kit

This is not a difficult job when using a Special Tool Kit (Illustration 11). It's very important not to rush, pull everything apart and throw away all the components you will replace. Clean up all the remaining parts and fit the new ones carefully, taking note of the very important points listed below, read the following instructions and cross them off once you have completed each point.

Very Important !



Illustr. 11



Illustr. 12

- The bearings in your handpiece are small and the balls in them are delicate, each time you go to hit the bearing “think first!” **The force must never travel through the balls** i.e.: if you are fitting the outer bearing into a casing (Illustration 12, Item 1) hit the outer rim only, not the seal or the inner rim. And when fitting the bearing onto a shaft (Illustration 12, Item 2) hit the inner rim only. If you do hit the wrong rim, or the seal, it will distort the balls, do not use this bearing anymore, throw it away as it will run hot and wear rapidly.



Illustr. 11

- Do not clamp the barrel in a vice.
- Use (replace) all the parts contained in the bearing kit.
- Never re-use old bearings. The bearings will have been damaged during removal.
- Do not use a steel hammer as this will jar and damage the tool and the bearing, use a nylon hammer or a piece of wood.
- Use a Special Tool Kit (Illustration 11) they are not expensive and will last a life time.
- Use a small piece of hard wood to work on as a bench.
- Make sure you know the difference between the distance washer and the wave washer. The wave washer is wobbly, the distance washer is flat.

Replace Bearings „Step by Step“

- Remove fork.
- Remove both cogs.
- Remove back joint spring and caps. The back half joint will now come apart.
- Remove the inner back half joint from the barrel.
- Remove the circlip using the circlip pliers.
- Clean the circlip groove thoroughly (this is important).
- Place the punch (tool no. C; Illustration 11) through the front of the barrel (Illustration 13) and onto the recess in the middle of the crankhead. Holding the barrel and punch in one hand gently knock the crank shaft free from the barrel. The bush, wave washer and front bearing will come with it. Don't allow the bush or the crank shaft to hit the floor as damage may occur.
- Remove the pin or worm drive.
- Slide the punch down where the pin or worm drive was removed, holding the outer back half joint (Illustration 19) in one hand gently knock out the old bearing and clean the back half joint **thoroughly**.
- Place outer back half joint ferrule thread down onto the piece of wood and select one of the smaller of the three bearings (Illustration 20), tap it gently into position using tool no. A.
- Remove inner back half joint bearing with the punch coming from the crank shaft head end (Illustration 19), holding the inner half back joint with one hand gently knock out the old bearing and clean the inner back half joint **thoroughly**.
- Place the front of the inner back half joint on the piece of wood and gently tap the smallest of the two remaining bearing (Illustration 20) into position using tool no. A.
- Remove front bearing (Illustration 14), put the small end of tool no. D onto the piece of wood, place the crank head inside the big end, the distance washer will now rest on the tool. Screw the thread inside tool no. B onto the crank shaft making the crank shaft twice as long, hit the tool until the bearing is free of its seating, unscrew the tool and remove the bearing and the distance washer.



Illustr. 11+ 13



Illustr. 19+20



Illustr. 14



Illustr. 21

- To fit the front bearing, place the crank head on the piece of wood (Illustration 21) with the pin facing down over the edge, place the distance washer (the flat one) over the crankshaft and then the remaining (biggest) bearing. Using tool no. B with the thread to the top hit the tool until the bearing is positioned against the seat behind the crank head. Take care that the distance washer does not get caught between the bearing and the seat behind the crank head, the distance washer should always be free moving



Illustr. 15

- Clean the barrel thoroughly (now is a good time to fit a rug if required).
- Ensuring all bearings are seated properly before beginning to reassemble.
- Place the mouth of the barrel on the piece of wood (Illustration 15) and lower the crankshaft with bearing fitted into the barrel, slide small end of tool no. D into the barrel and gently tap the tool until it rests against the end of the barrel.



Illustr. 10

- Place the new wave washer over the crank shaft and lower it onto bearing.
- Clean the bush and coat it and the inside of the barrel with light oil, slide the bush down on top of the wave washer.
- Fit **NEW** circlip (do not over compress the circlip when fitting because it will rub on the inner back half joint and make the back end tight) inside the barrel, then using the small end of tool no. D against the circlip, tap the circlip into its seat. Make sure the circlip is seated properly in the groove.



Illustr. 22

- Reassemble the two back half joints with new grease in the back joint caps.
- Place a **NEW** seal over the inner back half joint (see back joint removal and replacement and Illustration 10) and oil liberally.
- Coat inner back half joint and inside of barrel with oil and slide inner back half joint into the barrel and screw the cog onto the end of the crankshaft.
- Reassemble the worm or pin drive and cog.
- Refit the fork making sure the flat side of the ball is facing the crank shaft (Illustration 22).

Fitting Pin Drive Pin

The pin drive pin is tapered, identify the small end of the broken pin and tap this small end of the pin with a punch to remove it. Tap in the new pin gently, don't hit it hard or you will crack the end of the shaft. Place the big end of your pin on an anvil or something solid and round off (or burr over) the small end of the pin ensuring it is a good fit into the shaft, finish this job by filing the small end flush with the shaft. Make sure the big end does not protrude out past the outer rim of the drive coupling, if it does this will rub on the tube and run hot, file off the excess.



Illustr. 16

Adjust Centrepost using a Post Guide

The post has a notch in the bottom around from the screwdriver slot (Illustration 16). Use this notch as a setting mark and once you have the handpiece cutting well remember or write down where this mark is, this will enable you to reset the post to the original position should the need arise.

- Set a freshly ground comb and cutter that is 3mm thick.
- Apply normal tension to cutter.
- Move the cutter until the ball is at the bottom of the fork and the cutter is in the middle of the comb.
- Loosen the centre post lock nut.
- Insert the Post Guide (Illustration 17) in the hole and sit the first ledge on the fork at the front of the ball race.



Illustr. 17, 18

- Making sure at all times that you have a cutting tension on the cutter, adjust the centre post up or down until the second ledge sits on the front of the machine surface around the oil hole.
- Lock the centre post lock nut and recheck making sure that both ledges remain seated.
- When correctly set it will be as per Illustration 18.

6 Environmental Protection and Disposal

6.1 Introduction

The owner has a duty to dispose of the shearing blades as well as of the shearing handpiece properly at the end of its service life. Please observe your relevant national regulations.

6.2 Material Categories

Shearing blades and the whole shearing handpiece consist of high alloy steel and can be disposed at scrapping facilities.

7 Contact Addresses

Your purchasing point or the company shown on your guarantee certificate are authorised service centres or refer to the nearest service centre in your area.

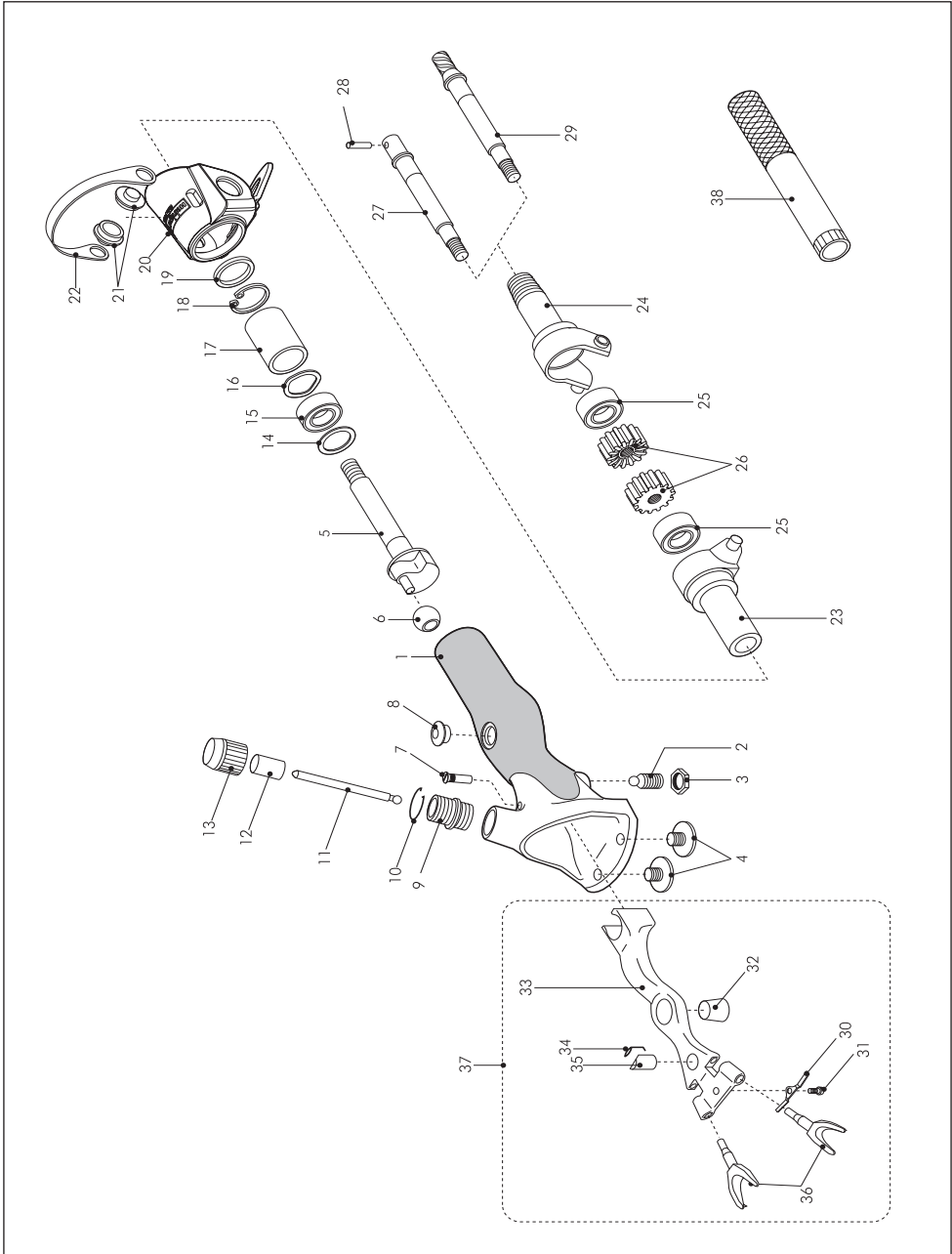

0

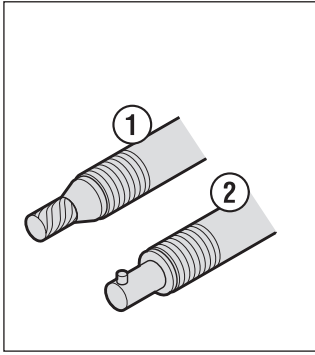

1

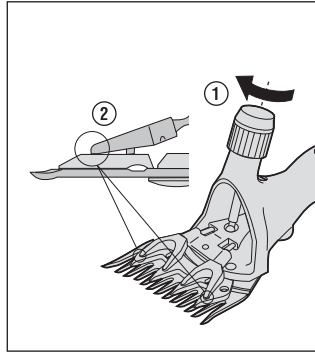

2

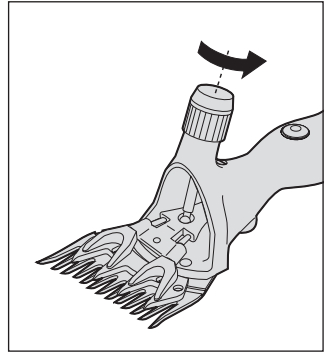

3

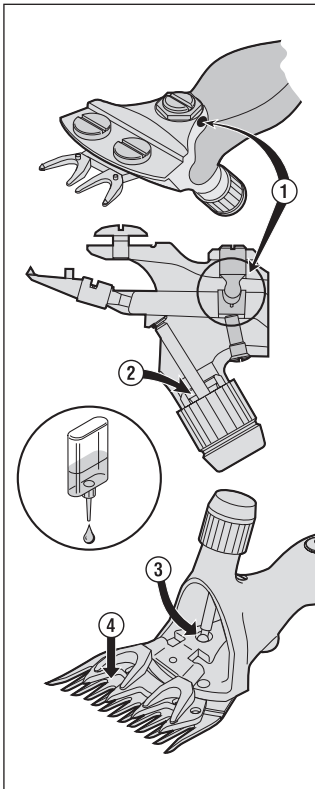

4

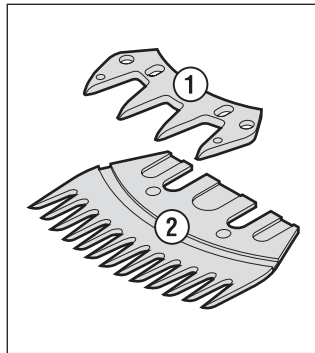

5

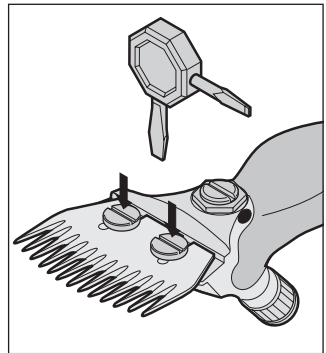

6

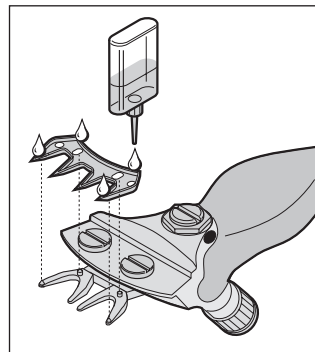

7

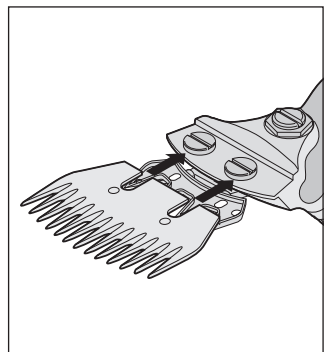

8

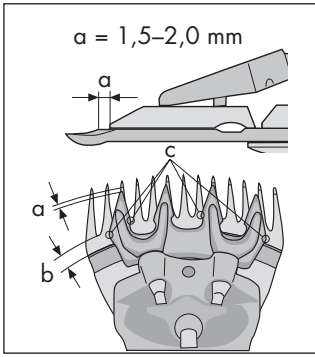

9

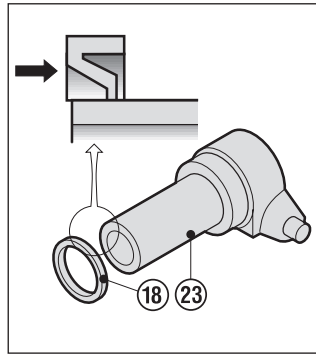

10

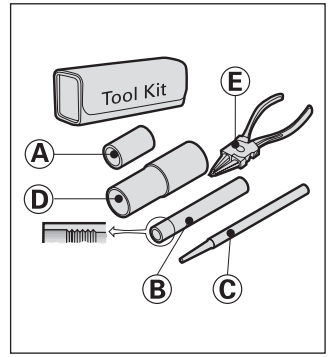

11

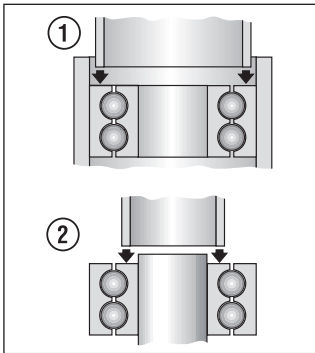

12

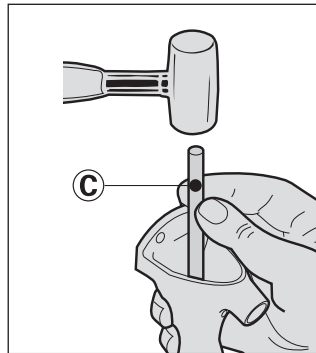

13

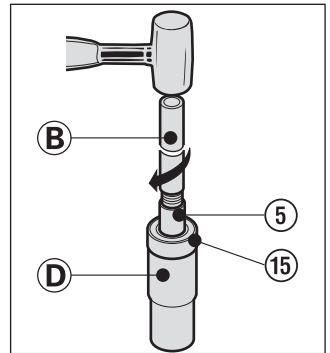

14

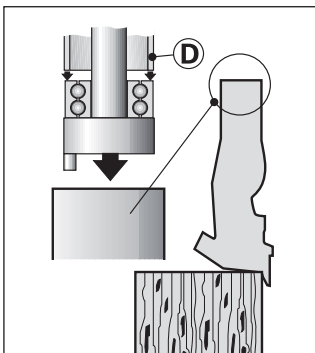

15

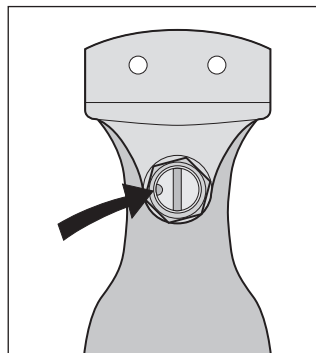

16

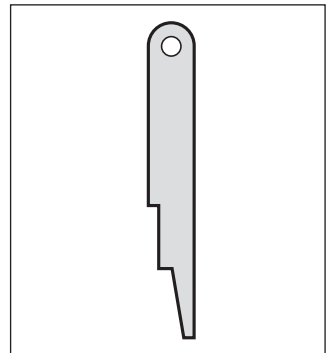

17

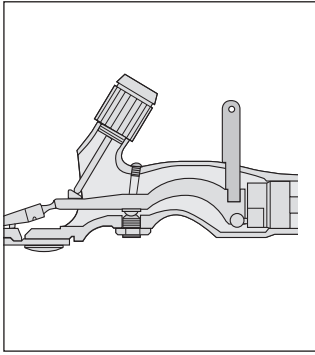

18

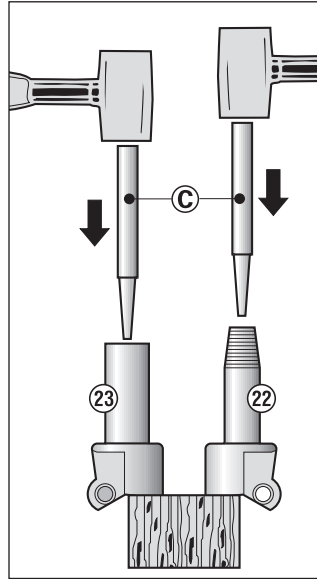

19

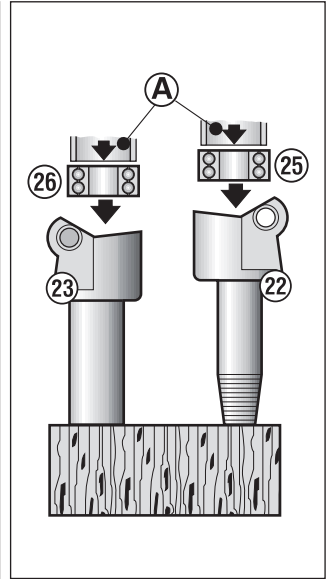

20

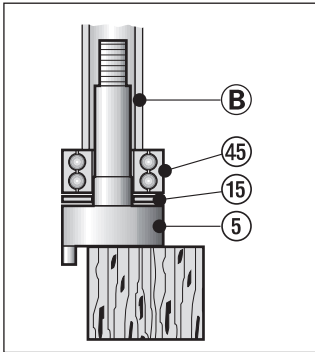

21

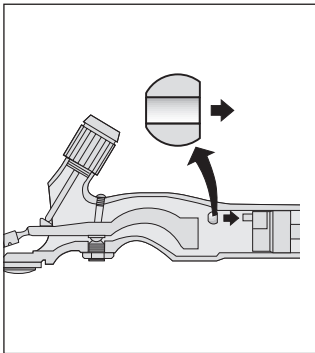

22



23

garantía
garantie
warranty

Artikel Item Article Artículo Artikkel	
Seriennummer Serial no. No. de série No. de serie Serie nummer	
Kaufdatum Date of purchase Date d'achat Fecha de compra Kjøpsdato	
Stempel und Unterschrift Stamp and signature Cachet et signature Sello y firma Stempel og underskrift fra forretningen	

In case of claim, please return your machine with the instruction manual and the warranty card directly to your local distributor. Please do not cut off the warranty card from the instruction manual.

En caso de garantía, devuelva su máquina con el manual de instrucciones y la carta de garantía directamente a su distribuidor local. Por favor no recorte la carta de garantía del manual.

En cas de garantie, retournez votre machine avec le mode d'emploi et la carte de garantie directement à votre distributeur local. Nous vous prions de ne pas couper la carte de garantie du mode d'emploi.

Im Garantiefall retournieren Sie Ihre Maschine mit der Bedienungsanleitung und Garantiekarte direkt Ihrem lokalen Händler. Trennen Sie die Garantiekarte bitte nicht aus der Bedienungsanleitung.

